

NOTES:

- OPERATING PRESSURE ~ 2000 P.S.I. MAX.
TEST PRESSURE ~ 2500 P.S.I.
TEST CYLINDER PER MCES-007

CAPACITY IN LBS. @ 2000 P.S.I.	
EXTEND	RETRACT
1st SLEEVE	71,567
2nd SLEEVE	51,933
3rd SLEEVE	35,440
PLUNGER	22,089

- SEAL KIT - 375 1804 003
CONSISTS OF ITEMS 1-4, 13-16, 29 & 30
- REBUILD KIT - 375 1804 022
CONSISTS OF ITEMS 1-4, 9-20 & 25-30
- MAXIMUM EXTEND FLOW - 40 GPM

- SERIAL NUMBER TAG LOCATION PER MCES-0001.
- APPLY LOCTITE #242 TO SET SCREWS PER HE STD 35-20.
APPLY 20-30 IN. LB OF TORQUE TO SET SCREWS.
- THIS IS A BLEEDERLESS DESIGN CYLINDER.
- SHIPPERS NOTE: EACH CYLINDER WILL HAVE "BLEEDERLESS INSTRUCTION TAG" ATTACHED WHEN SHIPPED.

37	372	6740	028	1	A3767-400K-28	MAIN CYLINDER ASS'Y
36	371	6745	073	1	A3867-450K-111	SA SLEEVE ASSEMBLY
35	371	5745	094	1	A3857-450K-144	SA SLEEVE ASSEMBLY
34	371	4745	049	1	A3847-450K-120	SA SLEEVE ASSEMBLY
33	373	3914	006	1	A3937-740K-6	SA PLUNGER ASSEMBLY
32	391	2282	030	2	PLUG,NPTF=(1.00X0.75L,0.62PHX-SKT,STL	
31	391	1281	005	2	FITTING=0.12NPT,0.75L,GREASE	
30	391	1431	141	4	SCREW,SET=0.25-20X0.38LG,HEX-DR,FLAT-PT	
29	391	0284	004	4	BALL=0.188DIA,NYL,GN	
28	375	9023	040	1	WEAR RING=7.580DX7.00IDX0.75W,BUTT,BRASS368	
27	391	2684	071	1	WEAR RING=6.250DX6.00IDX0.75W,BUTT,GL-NYL,GRV2	
26	391	2684	070	1	WEAR RING=6.250DX5.00IDX0.75W,BUTT,GL-NYL,GRV2	
25	391	2684	069	1	WEAR RING=4.250DX4.00IDX0.75W,BUTT,GL-NYL,GRV2	
24	375	3020	114	1	AG3020-1-67 STDP RING / 30-BEVEL	
23	375	3020	113	1	AG3020-1-57 STDP RING / 30-BEVEL	
22	375	3020	112	1	AG3020-1-47 STDP RING / 30-BEVEL	
21	375	3020	111	1	AG3020-1-37 STDP RING / 30-BEVEL	
20	391	3581	303	1	SPR,WAVE=7.380DX6.741DX0.12HP1327-677	
19	391	3581	302	1	SPR,WAVE=6.380DX5.741DX0.12HP1327-577	
18	391	3581	301	1	SPR,WAVE=5.380DX4.741DX0.12HP1327-477	
17	391	3581	300	1	SPR,WAVE=4.380DX3.741DX0.12HP1327-377	
16	375	9009	020	1	SEAL=7.380DX6.751DX1.12W,VP,HYTREL+RUBBER	
15	375	9009	019	1	SEAL=6.380DX5.751DX1.12W,VP,HYTREL+RUBBER	
14	375	9009	018	1	SEAL=5.380DX4.751DX1.12W,VP,HYTREL+RUBBER	
13	375	9009	034	1	SEAL=4.380DX3.751DX1.12W,VP,HYTREL+RUBBER	
12	391	2682	005	1	WEAR RING=7.380DX6.751DX1.00W,CENT,MNRL-NYL	
11	391	2682	004	1	WEAR RING=6.380DX5.751DX1.00W,CENT,MNRL-NYL	
10	391	2682	003	1	WEAR RING=5.380DX4.751DX1.00W,CENT,MNRL-NYL	
9	391	2682	002	1	WEAR RING=4.380DX3.751DX1.00W,CENT,MNRL-NYL	
8	391	1470	166	1	YA3011-67 PACKING NUT	
7	391	1470	165	1	YA3011-57 PACKING NUT	
6	391	1470	164	1	YA3011-47 PACKING NUT	
5	391	1470	163	1	YA3011-37 PACKING NUT	
4	375	9026	140	1	WIPER=7.140DX6.7451DX1.188W,PDL,YURETHANE	
3	375	9026	139	1	WIPER=6.140DX5.7451DX1.188W,PDL,YURETHANE	
2	375	9026	138	1	WIPER=5.140DX4.7451DX1.188W,PDL,YURETHANE	
1	375	9026	137	1	WIPER=4.140DX3.7451DX1.188W,PDL,YURETHANE	

S74DC-74-135.00		37		37						
ASS'Y, ENGR. NO.		39.31	48.44	134.75	13.0					
377 2514 125		1	Y	STROKE	Q.L.					
PART NO.	CONG. OF TUBS	W	Y	STROKE	Q.L.	DESCRIPTION	ITEM	FULL Q.L.	EXT. Q.L.	REF. Q.L.
						MAIN	37			
						1st. SLEEVE	36	31.81	2.88	2.5
						2nd. SLEEVE	35	33.00	2.88	13.0
						3rd. SLEEVE	34	34.19	2.88	
						PLUNGER	33	35.75	2.50	

0704-27
377 2514 125
REV. REVISIONS

ITEM	PART NO.	QTY	DESCRIPTION
S74DC-74-135.00 TYPE CYLINDER ASSEMBLY			
WEIGHT	375 LBS		
DATE	377 2514 125, SD		
REV			

Mobile Cylinder Div. Standard Telescopic Service Manual

Catalog HY18-0008/US Rev B

- aerospace
- climate control
- electromechanical
- filtration
- fluid & gas handling
- hydraulics
- pneumatics
- process control
- sealing & shielding



ENGINEERING YOUR SUCCESS.

 **WARNING - USER RESPONSIBILITY**

FAILURE OR IMPROPER SELECTION OR IMPROPER USE OF THE PRODUCTS DESCRIBED HEREIN OR RELATED ITEMS CAN CAUSE DEATH, PERSONAL INJURY AND PROPERTY DAMAGE.

This document and other information from Parker-Hannifin Corporation, its subsidiaries and authorized distributors provide product or system options for further investigation by users having technical expertise.

The user, through its own analysis and testing, is solely responsible for making the final selection of the system and components and assuring that all performance, endurance, maintenance, safety and warning requirements of the application are met. The user must analyze all aspects of the application, follow applicable industry standards, and follow the information concerning the product in the current product catalog and in any other materials provided from Parker or its subsidiaries or authorized distributors.

To the extent that Parker or its subsidiaries or authorized distributors provide component or system options based upon data or specifications provided by the user, the user is responsible for determining that such data and specifications are suitable and sufficient for all applications and reasonably foreseeable uses of the components or systems.

Offer of Sale

The items described in this document are hereby offered for sale by Parker Hannifin Corporation, its subsidiaries or its authorized distributors. This offer and its acceptance are governed by the provisions stated in the "Offer of Sale".

© Copyright 2009, Parker Hannifin Corporation, All Rights Reserved

Safety Precautions for Single-Acting Telescopic Cylinders..... 4-5

Safety Precautions for Double-Acting Telescopic Cylinders..... 6-7

General Information 8-9

Service Parts and Required Tools..... 10-12

Normal Maintenance Items 13

Telescopic Cylinder Disassembly..... 14-15

Telescopic Cylinder Assembly..... 16-17

Telescopic Cylinder Operation..... 18-21

Standard Test Procedure 22

Storage and Installation..... 23

Bleederless Telescopic 24-25

Hydraulic Oil Recommendations 26

Troubleshooting Hints..... 27-31

Parker Safety Guidelines 32

Offer of Sale 33

Safety Precautions for Single-Acting Telescopic Cylinders

WARNING!

Telescopic cylinders commonly installed on dumping vehicles are devices intended to provide only a lifting force. The cylinder is not a structural member, and is not designed for, nor intended to provide stability to the dumping vehicle. Rollover or lateral tilt can cause the cylinder to bend, buldge or separate causing the dump body to drop suddenly, resulting in severe injury or death and/or damage to the unit and cylinder, if the following warnings are not observed.

Hydraulic cylinders are not to be used as a stabilizer on a dump body or dump trailer. The hydraulic cylinder will not prevent the dump body or trailer from rollover or lateral tilt. The cylinder is strictly a lifting device and is not a structural member of the unit. Cylinders are not to be used as a means of stabilizing the unit.

The hydraulic cylinder mounted in the unit should be free to find its own trajectory line of extension, free of any lateral loading of the plungers. Misalignment of the top or bottom mountings, or mounting pins too tight, may cause scoring of the plungers, leaking, or improper sequencing which could cause the unit to upset.

The hydraulic cylinder will not withstand lateral or side pressure when the unit is leaning. Only activate the cylinder when the tractor and trailer are in a straight line (not jack-knifed). A jackknife position of the tractor with the trailer is not recommended when dumping. In a jackknifed position, the upper coupler pivots on bearings, contributing nothing to dump stability. When the tractor and trailer are straight, the coupler bearings are normally 34 inches apart, assisting in stabilizing the dump.

Do not activate the cylinder while on unlevel or soft ground, or during heavy crosswinds. Doing so may cause the unit to upset. Uneven terrain, causing the trailer wheels to be 3 1/2 inches to 4 inches higher than the other side, puts the top of the body 12 inches to 14 inches off center when the cylinder is fully extended. On fresh fill, loaded trailer wheels may sink on one side, again setting up potential tip over. On road construction, the crown is also critical on spread application, as in dumping on a slope. A 4 inch plus, height differential of wheels on an axle 8 feet wide, is another rollover potential. Do not attempt dumping operations in high gusty wind conditions. If possible, raise the dump body directly into the wind.

A blown tire or a severely under inflated tire can cause dump instability, when dumping. Always check tires visually for cuts or punctures by nails and metal. Make sure all tires are inflated properly. Proper tire inflation also improves wear and fuel economy.

Do not activate the cylinder while personnel or equipment are alongside or behind the dump body or trailer.

A hung load is commodity that does not discharge when a dump body is raised to an elevated position. This condition exists due to surface adhesion between the commodity and the interior of the dump body. To avoid a tip over due to a hung load, the driver should be warned by an observer or be aware of the material's moisture content, if this condition exists, immediately lower the dump body.

The operator should stay at the controls during the entire dumping operation. An operator who fails to stay at the controls will never control the body when it starts to lean over for a tip over. If a problem exists, and the body starts to lean, the operator should immediately lower the dump body or trailer and check and remedy any potential problems, then resume dumping the load. It is important to slowly position the cylinder control valve into the hold position to avoid subjecting the cylinder to a high pressure.

Do not overload the unit. The load must be distributed evenly during loading or unloading to avoid rollover and lateral tilt. Loads stuck while the cylinder is partially or completely extended increases the hazard of rollover and lateral tilt. Lower the dump body or trailer entirely with the cylinder control valve partially open (avoid lowering the dump body or trailer with the cylinder control valve completely open). Then unload the dump body or trailer manually or with an alternative mechanical aid.

Overloading is a very common occurrence that aggravates all the above conditions that cause a tip over.

Safety Precautions for Single-Acting Telescopic Cylinders

WARNING!

Shock pressure can cause severe injury or death and/or damage to the unit and cylinder.

Do not use the cylinder to loosen loads stuck in the dump body or trailer. Lower the dump body or trailer entirely with the cylinder control valve partially open (avoid lowering the dump body or trailer with the cylinder control valve completely open). Then unload the dump body or trailer manually or with an alternative mechanical aid.

Humping is a rapid acceleration / deceleration method used to loosen a hung load from a trailer. If the load is off center and the trailer is moved, a tip over may occur. Also, serious damage to the hoist may occur if an extreme humping motion is used to get a sticky load out of the body.

Do not move the truck and jam the brakes while the cylinder is partially or fully extended to loosen loads stuck in the dump body or trailer. Pulling forward (or backing up) and hitting the brakes, or lowering the body part way and then quickly engaging the valve in the "HOLD" or "RAISE" position will cause a tremendous pressure spike. This pressure spike may bulge or split one of the larger stages of the cylinder. Lower the dump body or trailer entirely with the cylinder control valve partially open (avoid lowering the dump body or trailer with the cylinder control valve completely open). Then unload the dump body or trailer manually or with an alternative mechanical aid.

Do not move the truck until the dump body or trailer is lowered completely.

WARNING!

Over pressurizing the cylinder can cause severe injury or death and/or damage to the unit and cylinder.

Do not operate a cylinder at pressures above factory recommended operating pressures (Normally 2,000 P.S.I. unless otherwise approved).

WARNING!

Worn or damaged hydraulic hoses can cause severe injury or death and/or damage to the unit and cylinder.

Hydraulic hoses should be checked regularly and replaced if worn out or damaged.

NOTICE!

Do not drive the unit while the P.T.O. or hydraulic pump is engaged.

The hydraulic oil should be checked and changed regularly to avoid contamination leading to internal cylinder damage.

A damp to light film of oil on each plunger indicates a good cylinder operation. A small accumulation of oil may be noticed on the plunger at the head nuts after many cycles. This should not be mistaken for packing leakage.

Cylinder should be free of entrapped air. It is advisable to bleed air from the cylinder weekly to free entrapped air. This will result in a smoother operation.

The cylinder should float in the pin mountings. The cylinder should be installed with 1/8" to 3/16" of clearance between the pin and the pin hole if the mounting eye is wider than 5", or with 1/16" to 1/8" clearance if the mounting eye is less than 5" wide. There should be a clearance of 1/8" to 1/4" per side on eyes less than 5" wide and 1/4" to 1/2" clearance per side on eyes in excess of 5" wide. This is to allow the body to sway slightly while dumping, without putting a side load on the cylinder. The cylinder plunger or one of the sleeves should be extended a minimum of 1/4" when the dump body is in the down position.

The cylinder end mounts should be lubricated regularly.

Safety Precautions for Double-Acting Telescopic Cylinders

WARNING!

Rollover or lateral tilt can cause severe injury or death and/or damage to the unit and cylinder.

The hydraulic cylinder will not prevent the unit from rollover or lateral tilt. The cylinder is strictly a lifting device and is not a structural member of the unit. Cylinders are not to be used as a means of stabilizing the unit.

The hydraulic cylinder mounted in the unit should be free to find its own trajectory line of extension and retraction so as not to cause improper sequencing and excessive wear to the plungers and internal components. Misalignment could cause the unit to upset. On longer stroke cylinders mounted horizontally, supports should be added to the center of the extended cylinder to increase the column strength of the cylinder.

The hydraulic cylinder will not withstand lateral pressure when the unit is leaning. Only activate the cylinder when the tractor and trailer are in a straight line (not jack-knifed). Do not activate the cylinder while on unlevel or soft ground, or during heavy crosswinds. Doing so may cause the unit to upset.

Do not activate the cylinder while personnel or equipment are alongside or behind the unit.

On roll-off units, lower the container with the control valve partially open (avoid lowering the container with the control valve completely open) to prevent pressure build-up in the reeving cylinders as gravity pulls the container to the ground.

WARNING!

Shock pressure can cause severe injury or death and/or damage to the unit and cylinder.

A double-acting telescopic cylinder should be fully retracted when not in use.

Do not extend the cylinder until it has been fully retracted. A partially extended cylinder with pressure relieved may drift out of position. This can happen if a cylinder experiences vibration, such as an ejector or push out cylinder does in a refuse body. If this happens and the cylinder is then extended, the out of position plunger or sleeves will rapidly reposition themselves and possibly cause high pressure oil to be trapped on the retract side of the cylinder. This could cause a stage / sleeve to bulge and or the packing and bearings to be blown out from under a head nut.

On roll-off units, do not pull a container onto the hoist until the lift cylinder(s) are completely extended. If the lift cylinders are not completely extended when a container is being pulled onto the hoist, the lift cylinders may be pulled open by the weight of the load. Then as the container is pulled over center, the cylinders will be forced closed until they hit the column of oil inside the cylinders causing a sudden pressure surge. If the lift cylinders are pulled open by the load, they should be extended with the control valve to fill them with oil before pulling the container on the rest of the way. Care should be taken if moving roll-off unit with tilt cylinders extended, avoiding sudden stops or jolts.

On roll-off units, care must be taken if a unit is moved with the lift cylinders extended. Avoid sudden stops or jolts.

On roll-off units dropping off a loaded container, feather control valve to avoid any pressure surges in the reeving / cable cylinders as gravity pulls the container to the ground.

On roll-off units, if the container is not evenly loaded and is heavy on one side, the lift cylinders may mis-stage. When the plunger / sleeves attempt to correct themselves, there may be a sudden pressure surge, possibly damaging the cylinder.

Check the cylinder operation to ensure the plungers extend in sequence with the largest diameter plunger moving first, then the next largest, etc. When retracting, the smallest plunger should move first, then the next smallest, etc. Mis-staging could cause the unit to upset and/or damage the cylinder due to excessive pressure build-up.

Safety Precautions for Double-Acting Telescopic Cylinders

WARNING!

Over pressurizing the cylinder can cause severe injury or death and/or damage to the unit and cylinder.

Do not operate a cylinder at pressures above factory recommended operating pressures (Normally 2,000 P.S.I. unless otherwise approved).

Hydraulic hoses should be checked regularly and replaced if worn out or damaged.

NOTICE!

Do not operate a packer / ejector cylinder with a misaligned blade. If the packer / ejector blade is bent, damaged, or if the blade slide shoes or guide track assembly are worn out, this can cause excessive side loading to the cylinder damaging it internally or bending a plunger or sleeve.

If the hydraulic system uses quick disconnects (such as on a transfer trailer) or holding / lock type valves, make sure they are properly connected. If not, oil may become trapped in the cylinder causing an excessive pressure build up and damage to the cylinder. This is particularly true if there is a blockage on the retract side of the cylinder and the cylinder is then extended. This could internally intensify the pressure 10 times or more inside the cylinder. (Example; The pump develops 2,000 P.S.I. trying to extend the cylinder, oil pressure trapped on the retract side of the cylinder could see 20,000 P.S.I.)

A double-acting telescopic cylinder normally requires at least 15 G.P.M. oil flow to retract properly. Make sure the hydraulic pump is developing the required flow.

Most double-acting telescopic cylinders will self bleed themselves of air. Upon installation of a new cylinder this will require cycling the cylinder approximately 10 times to the complete extend and retract positions with no load against it. Check to make sure stages sequence properly. When extending, the largest stage should move first then the next largest, etc. and when retracting, the smallest should move first then the next smallest, etc.

The hydraulic oil should be checked and changed regularly to avoid contamination leading to internal cylinder damage.

Grease the pin mountings regularly.

WARNING!

Before working on a telescopic cylinder mounted on a truck or trailer unit, use supports or holding devices that will absolutely prevent the body from accidentally lowering. Place control valve in the "LOWER" position to assure that all pressure has been relieved from the cylinder.

Hydraulic Cylinder Model Number Coding

The code and model numbers of a Parker (Commercial Hydraulics) Cylinder are references to its size and type. Using these numbers when ordering or inquiring greatly facilitates accurate understanding.

The following are examples of Parker Mobile Cylinder code and model numbers.

Single-acting Telescopic
S63MB-9-120
① ② ③ ④ ⑤ ⑥ ⑦

Double-acting Telescopic
SD96CC-3-199
① ② ③ ④ ⑤ ⑥ ⑦

Double-acting Piston Rod
D72LB-11-83
① ② ④ ⑤ ⑥ ⑦

- S = Single-acting Telescopic or Displacement Cylinder**
(Commercial has also used SA, SF, and H as a prefix)
SD = Double-acting Telescopic Cylinder
D = Double-acting Piston Rod Cylinder
- = Nominal O.D. of the largest moving stage on Single-acting and Double-acting Telescopic cylinders**
or the
Nominal Bore of Double-acting Piston Rod Cylinders
- = Number of moving stages or sleeves in a Telescopic Cylinder**
- = Mounting option on the body or base end of cylinder**
- = Mounting option on the rod or plunger end of cylinder**
- = Modification or design variation of the cylinder**
- = Length of cylinder stroke in inches**

OUR DESIGN ADVANTAGES INCLUDE:

- * Longer sleeve overlap for improved stability and higher column loading.
- * Nylon tipped set screws that conform to the shape of the packing nut threads. It is nearly impossible for the packing nut to back off accidentally.
- * Snap-on, glass-filled bearings that absorb contaminants without damaging cylinder walls.
- * Threaded steel stop rings for easier servicing and more reliable stopping action.
- * External packing nuts give added support to the tube exterior while making service procedures easier.
- * Wave springs and chevron packing for self-compensating seals.
- * Hytrel rod wipers that resist higher temperatures without extrusion.
- * Positive manual air bleeder prevents cavitation and "mushy" cylinder action. **NOW BLEEDERLESS**
- * Cast steel mountings offer dependable strength. Pin-eye and rod-end are welded into a single unit.

Hydraulic Cylinder Load & Displacements

“ S ” SERIES SINGLE-ACTING, SINGLE & MULTIPLE STAGE CYLINDERS

Sleeve or Plunger O.D. (in inches)	Effective Area in square inches	Load Capacity lbs @ 2000 p.s.i.	Displacement per inch of stroke in gallons *
1.75"	2.41"	4,811	0.010
2.75"	5.94"	11,880	0.026
3.75"	11.04"	22,089	0.048
4.75"	17.72"	35,441	0.077
5.75"	25.97"	51,935	0.112
6.75"	35.78"	71,570	0.155
7.90"	49.02"	98,034	0.212
9.38"	69.03"	138,059	0.299
10.75"	90.76"	181,526	0.393
12.50"	122.72"	245,438	0.531
14.00"	153.94"	307,877	0.666

“ SD ” SERIES DOUBLE-ACTING, MULTIPLE STAGE CYLINDER

Sleeve or Plunger O.D. (in inches)	Bore of Main or Sleeve (in inches)	Effective area (sq. inches) to extend	Effective area (sq. inches) to retract	Load capacity lbs @ 2000 p.s.i. extending	Load capacity lbs @ 2000 p.s.i. retracting	Displacement per inch of stroke (in gallons)* to extend	Displacement per inch of stroke (in gallons)* to retract
1.75"	2.25"	3.98"	1.57"	7,952	3,142	0.017	0.007
2.75"	3.25"	8.29"	2.35"	16,592	4,712	0.036	0.010
3.75"	4.25"	14.18"	3.14"	28,372	6,283	0.061	0.014
4.75"	5.25"	21.64"	3.92"	43,296	7,854	0.094	0.017
5.75"	6.25"	30.68"	4.71"	61,360	9,426	0.133	0.020
6.75"	7.25"	41.28"	5.49"	82,564	10,994	0.179	0.024
7.90"	8.44"	55.68"	6.97"	111,360	13,946	0.242	0.030
9.38"	9.88"	76.59"	7.56"	153,180	15,120	0.332	0.033
10.75"	11.50"	103.87"	13.11"	207,738	26,213	0.450	0.057
12.50"	13.00"	132.73"	10.01"	265,465	20,028	0.575	0.043
14.00"	14.50"	165.13"	11.19"	330,261	22,384	0.715	0.048

Note: The Effective area to RETRACT a Standard “SD” series double acting multiple stage cylinder is the effective area of the PLUNGER (plunger bore area minus the plunger O.D. area).

Example: Retract force for a SD94CC-8-190 (which has 5.75" O.D. plunger and fits in 6.25" bore) would be 9,426 lbs @ 2,000 psi, based on a 4.71 sq. in. effective area.

To calculate effective area in square inches: Multiply diameter times diameter times .78

Example: 5 dia. x 5 dia. = 25 x .78 = 19.63 Square inches of area

To calculate load capacity / cylinder force: Multiply effective area times operating pressure (psi)

Example: 19.63 Square inches x 1750 P.S.I = 34,361 lbs of force

To calculate the required gallons of fluid to extend a cylinder:

Add each “Displacement per inch of stroke” (from chart) for the required sleeve sizes.

Divide this total by the number of moving sleeves, then multiply that total by the desired cylinder stroke.

Note: The “Gallons required to extend” does not include the necessary fluid to fill an empty cylinder.

Example: Required fluid to extend a S83DC-40-134 single-acting telescopic cylinder with following stage sizes:

5.75" O.D.= .112

6.75" O.D.= .155

7.90" O.D.= .210

.477

.447 ÷ 3 = .159 gallons per inch of stroke

.159 gallons per inch x 134" of stroke = 21.31 gallons to extend cylinder

Genuine Replacement Service Parts

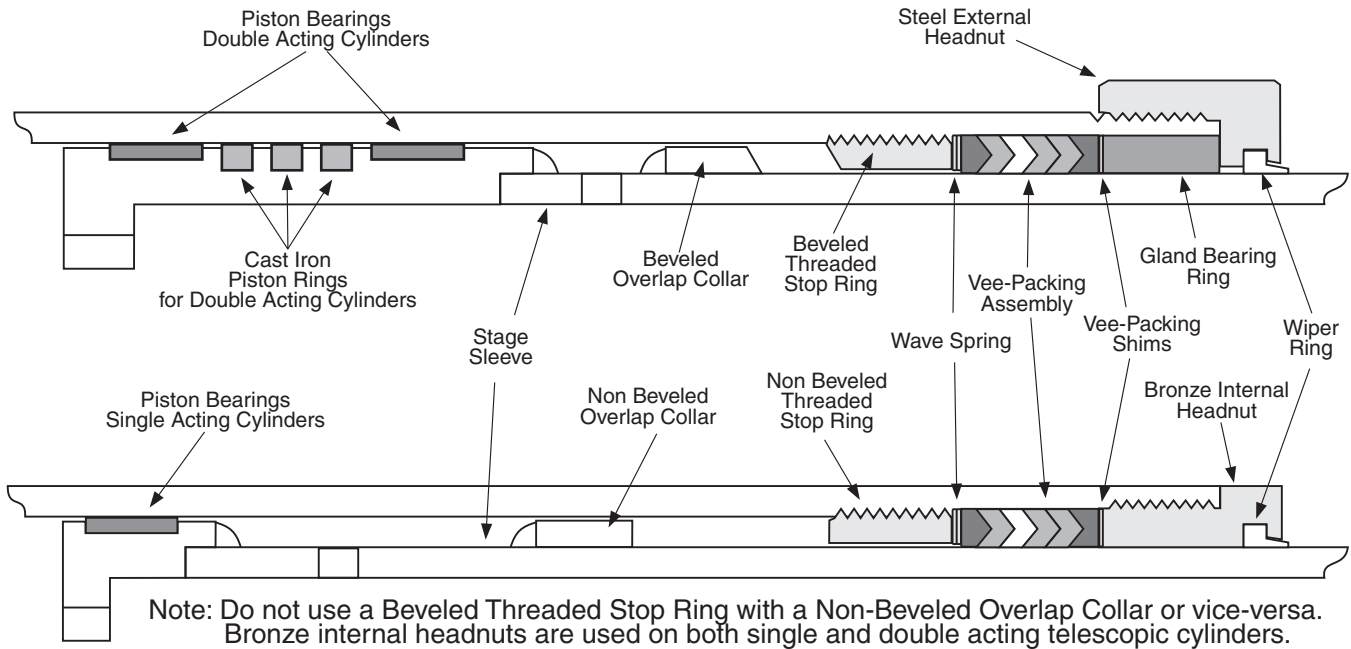

Following are service parts used on **STANDARD DESIGN COMMERCIAL** cylinders

Note: Commercial Hydraulics manufactures many different types and designs of cylinders. If you are not sure of service parts required please refer to the Cylinder Assembly print.

Description	2.75" Stage	3.75" Stage	4.75" Stage	5.75" Stage	6.75" Stage	7.905" Stage	9.375" Stage
Vee-Packing Assembly with Shims	375-9009-017 AJ3009-27	375-9009-034 AJ3009-37	375-9009-018 AJ3009-47	375-9009-019 AJ3009-57	375-9009-020 AJ3009-67	375-9009-021 AJ3009-79	375-9009-022 AJ3009-93
Wiper Ring	375-9026-136	375-9026-137	375-9026-138	375-9026-139	375-9026-140	375-9026-141	375-9026-142
Gland Bearing Glass Filled Nylon	391-2682-001 J1003-1-1	391-2682-002 J1003-1-2	391-2682-003 J1003-1-3	391-2682-004 J1003-1-4	391-2682-005 J1003-1-5	391-2682-006 J1003-1-6	391-2682-007 J1003-1-7
Gland Bearing Bronze	375-9003-064 AH1003-27	375-9003-044 AH1003-37	375-9003-045 AH1003-47	375-9003-046 AH1003-57	375-9003-063 AH1003-67	375-9003-041 AH1003-79	375-9003-066 AH1003-93
Wave Spring	391-3581-320 P1327-27	391-3581-300 P1327-37	391-3581-301 P1327-47	391-3581-302 P1327-57	391-3581-303 P1327-67	391-3581-304 P1327-79	391-3581-310 P1327-93
Threaded Stop Non-Beveled	375-4020-001 F4020	375-3020-002 F3020	375-6020-002 F6020	375-5020-001 F5020	375-7020-001 F7020	375-8020-001 F8020	375-9020-001 F9020
Threaded Stop Beveled	375-3020-110 AG3020-1-27	375-3020-111 AG3020-1-37	375-3020-112 AG3020-1-47	375-3020-113 AG3020-1-57	375-3020-114 AG3020-1-67	375-3020-120 AG3020-2-79	375-3020-119 AG3020-2-93
Piston Bearing Glass Filled Nylon	391-2684-123 U3023-32	391-2684-069 U3023-42	391-2684-070 U3023-52	391-2684-071 U3023-62	391-2684-072 U3023-72	391-2684-073 U3023-84	391-2684-098 U3023-98
Piston Bearing Bronze	N/A	375-9023-079 AM3023-42	375-9023-038 AM3023-52	375-9023-039 AM3023-62	375-9023-040 AM3023-72	375-9023-041 AM3023-84	375-9023-042 AM3023-98
Cast Iron Piston Ring	391-2683-010 X78-3.25-1	391-2683-014 X78-4.25	391-2683-019 X78-5.25	391-2683-024 X78-6.25	391-2683-029 X78-7.25	391-2683-034 X78-8.437	391-2683-042 X78-9.88
Steel External Headnut	391-1470-162 YA3011-27	391-1470-163 YA3011-37	391-1470-164 YA3011-47	391-1470-165 YA3011-57	391-1470-166 YA3011-67	391-1470-167 YA3011-79	391-1470-177 YA3011-93
Bronze Internal Headnut	391-1470-079 MA3011-27	391-1470-070 MA3011-37	391-1470-071 MA3011-47	391-1470-072 MA3011-57	391-1470-073 MA3011-67	391-1470-074 MA3011-79	391-1470-075 MA3011-93

Repair Kits

For Standard Parker (Commercial) Single-acting, Dump Body Cylinders.

Parker's genuine replacement parts are available in kits to rebuild or repack our dump body cylinders. These parts are the same as originally installed.

As with all hydraulic repairs, be sure your shop is properly equipped and that the work area is clean.

Rebuilding kits consist of:

- | | |
|------------------------|--------------------|
| 1. Wiper Rings | 5. Piston Bearings |
| 2. Packing Assemblies | 6. Set Screws |
| 3. Gland Bearing Rings | 7. Nylon Balls |
| 4. Wave Springs | |

Repacking kits consist of:

- | | |
|----------------|-----------------------|
| 1. Wiper Rings | 2. Packing Assemblies |
|----------------|-----------------------|

Ordering Information

Please order by part number

Cylinder Model	Rebuild Kit Number		Repack Kit Number	
	S53 Series	A300-253	375-1804-017	A300-11
S62 Series	A300-256	375-1804-020	A300-262	375-1804-026
S63 Series	A300-254	375-1804-018	A300-104	391-1804-109
S64 Series	A300-257	375-1804-021	A300-230	391-1804-237
S73 Series	A300-255	375-1804-019	A300-238	375-1804-002
S74 Series	A300-258	375-1804-022	A300-239	375-1804-003
S84 Series	A300-259	375-1804-023	A300-49	391-1804-054
S85 Series	A300-260	375-1804-024	A300-22	391-1804-060
S95 Series	A300-261	375-1804-025	A300-240	375-1804-004

Cylinder Packing Installation

Remove shims from packing set and measure packing height under finger pressure. Add one shim for each 1/32" that the packing measures under 1-1/8". Measure depth to top of stop ring from top of tube. This dimension should be 2-1/4", however, it may vary slightly due to seating of the stop ring. Add one shim to the packing set for every 1/32" that this dimension measures over 2-1/4" or remove one shim from the packing set for every 1/32" that this dimension measures under 2-1/4". Install wave spring with gap edge against top of the cylinder stop ring. Soak packing in hydraulic oil for a few minutes. (Check bottom adaptor. Only hard type can be used with the wave spring). Install packing, one ring at a time, in the proper sequence as shown in the sketch. Note: The soft, low pressure ring must be in the second position from the pressure side. Installed packing height need not be checked because wave spring will vary this

dimension. Installation of bearing and packing nut will compress wave spring for proper packing pre-load. Pull down tight against tube.

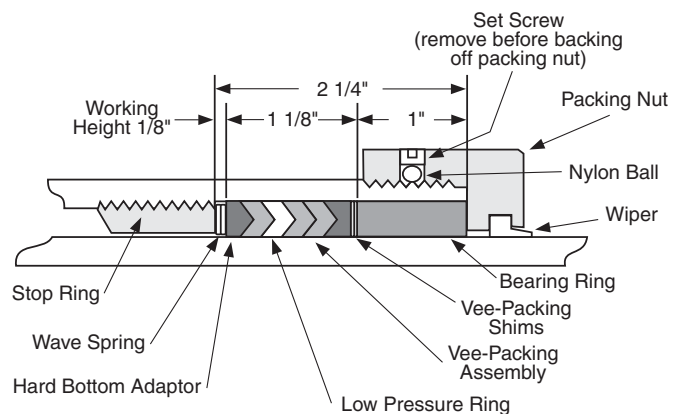

Hydraulic Cylinder Required Service Tools

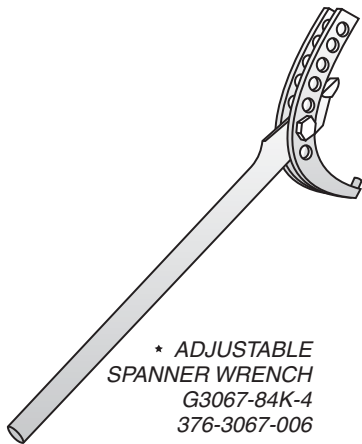

* ADJUSTABLE
SPANNER WRENCH
G3067-84K-4
376-3067-006

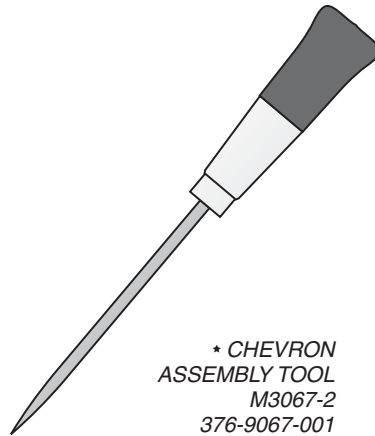

* CHEVRON
ASSEMBLY TOOL
M3067-2
376-9067-001

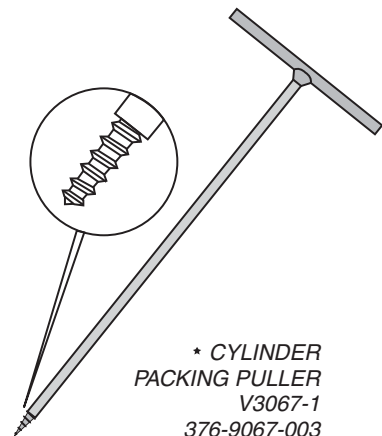

* CYLINDER
PACKING PULLER
V3067-1
376-9067-003

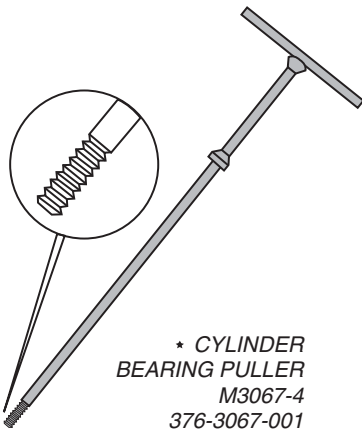

* CYLINDER
BEARING PULLER
M3067-4
376-3067-001

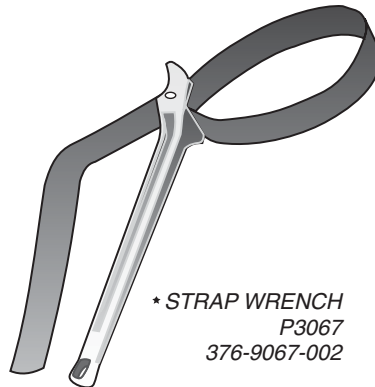

* STRAP WRENCH
P3067
376-9067-002

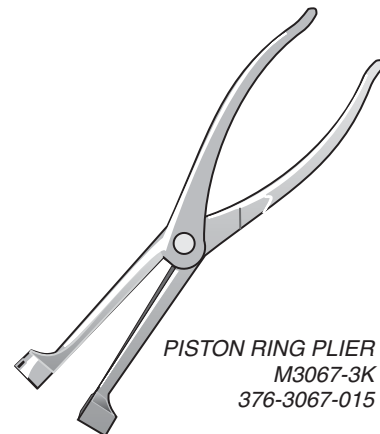

PISTON RING PLIER
M3067-3K
376-3067-015

Tools Required

Proper tools make the job of servicing cylinders easier and faster and reduce the possibility of damaging the finely machined surfaces. We recommend that you have the tools shown on this page prior to attempting service on Commercial telescopic cylinders. Tools with an * are required for all cylinders regardless of size. Lifting rings and stop ring wrenches must be ordered to fit the specific sleeve in the cylinder.

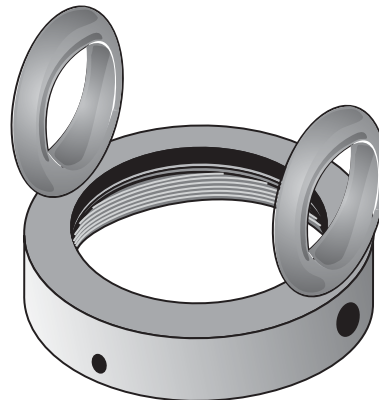

Lifting Ring
BC3067 Series

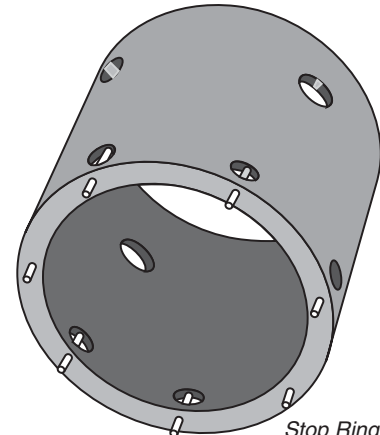

Stop Ring Wrench
BA3067 Series

Sleeve or
Main O.D. Eng # , Part Number

3 3/4"	BC3067-1, 376-3067-008
4 3/4"	BC3067-2, 376-3067-009
5 3/4"	BC3067-3, 376-3067-010
6 3/4"	BC3067-4, 376-3067-011
7 7/8"	BC3067-5, 376-3067-012
9 3/8"	BC3067-6, 376-3067-013
11 1/8"	BC3067-7, 376-3067-014

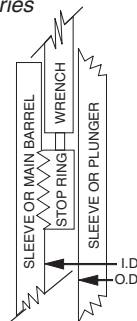

Sleeve or
Main I.D. Plunger O.D. Eng # , Part Number

3 1/4"	2 3/4"	BA3067-1, 376-6067-047
4 1/4"	3 3/4"	BA3067-2, 376-6067-048
5 1/4"	4 3/4"	BA3067-3, 376-6067-049
6 1/4"	5 3/4"	BA3067-4, 376-6067-050
7 1/4"	6 3/4"	BA3067-5, 376-6067-051
8 7/16"	7 7/8"	BA3067-6, 376-6067-052
9 7/8"	9 3/8"	BA3067-7, 376-6067-053

Normal Maintenance Items

Packing, wipers and bushings are considered normal maintenance or service items. These items are subject to contamination from external and internal foreign materials, many of which are abrasive in nature, causing abnormal wear or damage to the parts, to the extent that replacements are required.

WARNING!!

Before working on a telescopic cylinder mounted on a truck or trailer unit, use supports or holding devices that will absolutely prevent the body from accidentally lowering. Place control valve in the “Lower” position to assure that all pressure has been relieved from the cylinder.

Because of our self-compensating Packing design, Standard Parker / Commercial Cylinders require no packing adjustment. For Parker Packing Assembly Installation Procedure see Service Repair Kit Page.

Procedure for Adjusting Telescopic Cylinder Head Nuts. (For Cylinder designs using no Wave Springs and/or no U-Seals)

1. Loosen set screw (or set screws) in head nut that holds in packing of leaking stage.
2. Lightly tap head nut around circumference with a hammer.
3. Back head nut off 1/2 to 1 full turn using a spanner or chain wrench.
(Note: If stage rotates when head nut is turned, hold stage with a strap wrench.)
4. Cycle cylinder 2 to 3 times to reset chevron vee packing.
5. Retighten head nut approximately 1/2 turn further than it was when it was loosened.
6. Tighten set screws.

Procedure for Mis-Staging or Mis-Sequencing Cylinder.

1. Loosen set screws in head nut that holds in packing which fits over stage that is sticking.
2. Lightly tap head nut around circumference with a hammer.
3. Back head nut off 1/2 turn using a spanner or chain wrench.
4. Cycle cylinder, if cylinder still mis-stages, back head nut off another 1/2 turn.
5. Cycle cylinder, if cylinder still mis-stages, tighten the head nut of the next stage that is extending.
6. Tighten set screws.

Bleeding Air from Single-Acting Telescopic Cylinders.

For smooth operation of these cylinders, it is advisable to bleed the air from the cylinder weekly.

Manual bleeding is accomplished by:

1. Empty the dump body of any material.
2. Remove the cover plate from the dog house of the dump body to access the bleeder valve.
3. Fully extend the cylinder, raising the EMPTY dump bed.
4. Lower the dump to within 1 foot from resting on the frame.
5. With the fingers, turn the bleeder valve in a counterclockwise direction. This opens the valve and allows the air to escape from the cylinder.
6. When a steady stream of oil comes from the bleeder, turn the valve in a clockwise direction until it is closed.

**If these procedures fail to correct the problem, please contact an
Authorized Service Center for Instructions.**

Telescopic Cylinder Disassembly

Start Disassembly...

Open the air release valve (if equipped), remove the port pipe plugs and drain all of the oil out of the cylinder.

We recommend draining the oil from the cylinder before hoisting it to the vertical work stand position. It is easiest to drain oil when the cylinder is in a horizontal position and with the port down and open. Rotate the last plunger so the bleeder hole is on top and open. If you don't drain the oil, oil will squirt out as each tube is removed.

Step 2 ...

Firmly secure the cylinder in place with the rod end up to a sturdy workbench or a suitable stand that has access to an overhead crane.



Step 3 ...

Remove the grease fitting and air release valve with an open end wrench or an adjustable crescent wrench.



Step 4 ...

Remove pipe plugs on double-acting telescopic cylinders with an adjustable crescent wrench.

Step 5 ...

Clean head nut thread area, spray with WD-40 (penetrating oil).



Step 6 ...

Remove set screws from all packing nuts with a 1/8" Allen wrench.

Step 7 ...

Remove all packing nuts with adjustable spanner wrench, G3067-84K-4, Starting with the smallest thru the largest.



If the nut will not move, a sharp rap with a blunt chisel or rod may be required to jar the nut loose. If using a punch to break loose head nut, be careful not to damage threads.

Step 8 ...

Remove and discard old nylon slugs, which were in packing nuts.

Step 9 ...

Remove the wiper seal from the packing nut. Discard the old wiper seal.



Step 10 ...

Telescopic Cylinder Disassembly

Clean the thread and bearing area with a solvent and a clean, lintless rag.

Step 11 ...

Remove all bearing rings with two bearing ring pullers M3067-4.



Step 12 ...

Remove all packing with packing puller V3067-1.



Or extend the plunger or sleeve out about one foot. Wrap masking tape around a clean area on the plunger or sleeve. Push plunger or sleeve back into and past the packing and pull out. Packing will usually pop out, if not, repeat the process.



Step 13 ...

Remove wave spring from packing recess with a narrow screwdriver.



Step 14 ...

Remove stop rings from all stages with stop ring wrenches BA3067 series. If the stop ring will not move, a sharp rap may be required to jar the ring loose. If the sleeve containing the stop ring turns during removal, it should be held with a nylon strap wrench P3067.

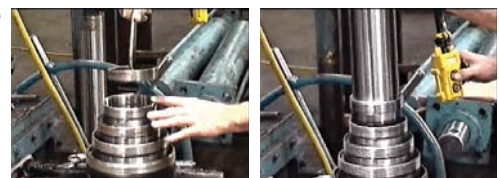

Step 15 ...

Removal of the plunger or sleeve will lift out the stop ring and expose the piston bearing ring. Use lifting ring tool series BC3067 to lift out the sleeves.

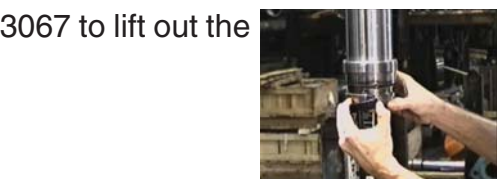

Step 16 ...

Remove piston bearing ring by hand.

Step 17 ...

Remove piston rings on double-acting cylinders with piston ring plier M3067-3K and remove piston bearing ring or rings by hand.

Step 18 ...

Repeat with remaining sleeves

Telescopic Cylinder Assembly

Assembly...

All bores in the packing area and plunger outside diameters must be free of tool marks and scratches. Polish with a fine paper, crocus cloth or a Scotch Brite pad. All parts should be clean and free of any contamination.

Start Assembly...

Starting with the largest sleeve,

Assemble piston bearings to all sleeves and plunger by hand.

Note; use bronze piston bearing on largest sleeve if piston passes port.

Assemble piston rings on double-acting cylinders using piston ring pliers M3067-3K.

Note; stagger cast iron piston rings.

Next, lubricate the piston bearing with grease.

Step 2...

Place the sleeve into the assembly using the proper lifting ring in the BC3067 series.

Step 3...

Lubricate the stop ring with grease and slide it onto the sleeve with its wrench holes up.

Slide threaded stop ring onto the sleeve and lower into the assembly.

Thread the stop ring into the assembly with the proper stop ring wrench in the BA3067 series. Turn the stop ring wrench counter-clockwise slowly for several turns, until a subtle “click” is heard or a slight settling of the wrench is felt. This indicates that the start points of the internal and external threads are aligned for engagement.

Next, turn the wrench clockwise until the stop ring bottoms out.

Bottom out stop ring with a sharp rap. If sleeve turns during assembly, it must be held with strap wrench P3067.

Measure stop ring depth. The stop ring should bottom out at a depth of $\frac{1}{4}$ ".

Note; Check if Beveled or Non-beveled Stop Rings and Overlap Collars. Do not use a Beveled Stop Ring with Non-Beveled Overlap Collar or visa versa.

Step 4...

Install wave spring with gap edge against top of the cylinder stop ring.

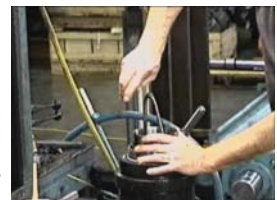

Telescopic Cylinder Assembly

Step 5...

Remove shims from packing set and measure packing height under finger pressure. Add one shim for each $\frac{1}{32}$ " that the packing measures under $1\frac{1}{8}$ ". Measure depth to top of stop ring from top of tube. This dimension should be $2\frac{1}{4}$ ", however, it may vary slightly due to seating of the stop ring. Add one shim to the packing set for every $\frac{1}{32}$ " that this dimension measures over $2\frac{1}{4}$ " or remove one shim from the packing set for every $\frac{1}{32}$ " that this dimension measures under $2\frac{1}{4}$ ".

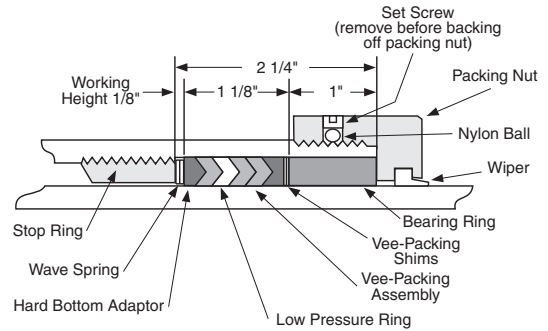

Step 6...

Soak packing in hydraulic oil for a few minutes. (Check bottom adaptor. Only hard type can be used with the wave spring). Install packing, one ring at a time, in the proper sequence as shown in the sketch. Note: The soft, low pressure ring must be in the second position from the pressure side. Installed packing height need not be checked because wave spring will vary this dimension. Installation of bearing and packing nut will compress wave spring for proper packing pre-load. Pull down tight against tube.

Step 7...

Install gland bearing ring with tapped holes showing.

Step 8...

Install new wiper seals in all packing nuts.

Step 9...

Apply anti-seize compound to the sleeve threads.

Step 10...

Install packing nut and tighten with the adjustable spanner wrench G3067-84K-4, if packing height is proper packing nut will bottom out.

Step 11...

Repeat steps 1 through 10 for remaining sleeves and plunger.

Step 12...

Install new nylon balls and set screws into all packing nuts and tighten with $\frac{1}{8}$ " Allen wrench.

Step 13...

Install air release or pipe plugs as applicable.



Single Acting Telescopic Cylinder Operation

Extending

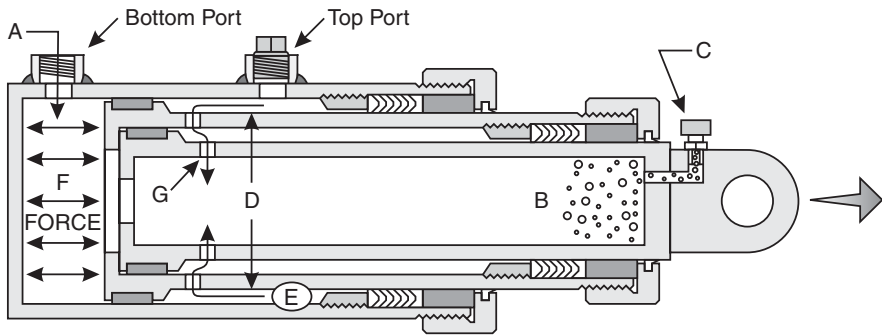

To Extend:

High pressure oil from the pump is directed by the control valve through the port (A) to fill the cylinder. Any air in the system is trapped in the end of the cylinder (B) and may be bled off through the bleeder valve (C).

Generally, bleeding is only necessary on initial start up or if air has been allowed to enter the system (Note: the bleeder valve must be located at the highest part of the cylinder).

Oil pushes on the bottom of the sleeve or plunger forcing (F) it to move out. The outside diameter or sealing area of the moving sleeve or plunger (D) determines the effective area.

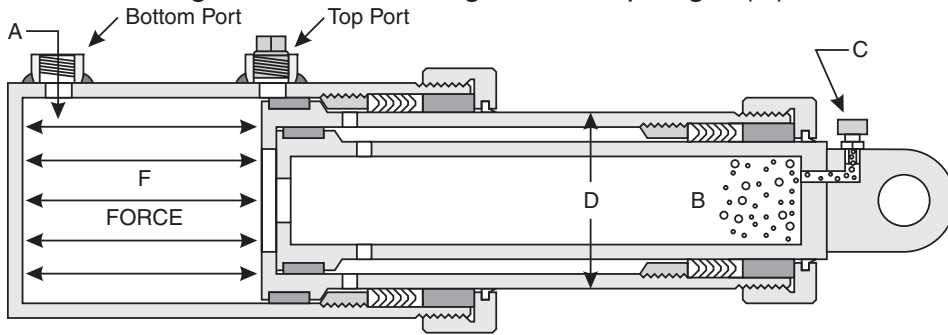

As the sleeve or plunger moves out, the oil trapped between (E) the sleeve or plunger wall is released through transfer holes (G) which are drilled in the sleeve or plunger.

Under normal operating conditions the largest diameter moving sleeve extends first, then the next largest sleeve, etc.

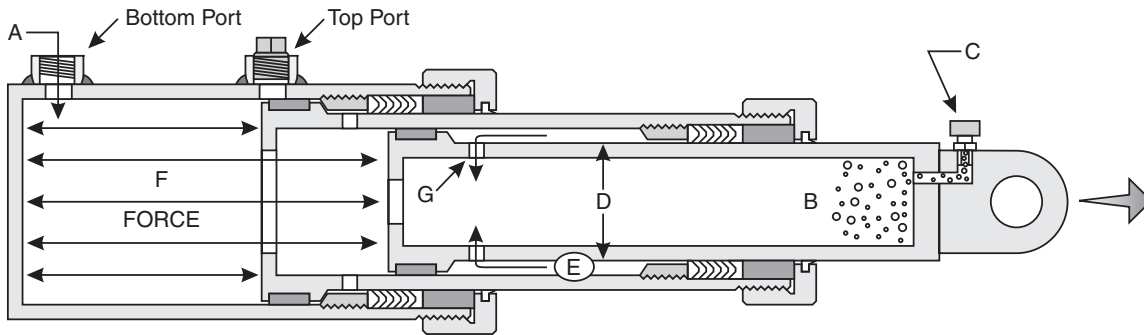

So at a given PSI (pressure) and GPM (gallons per min.) the cylinder will develop less force and increase in speed as it changes to the next moving stage.

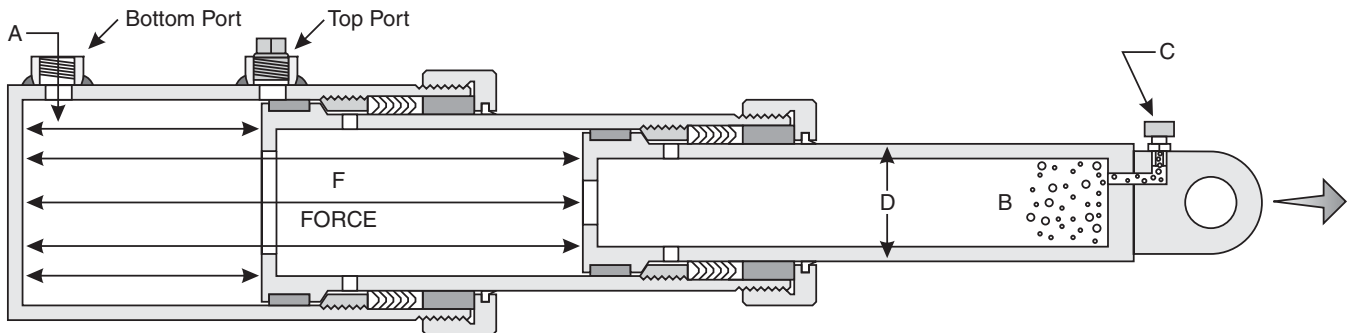

Single Acting Telescopic Cylinder Operation

Retracting

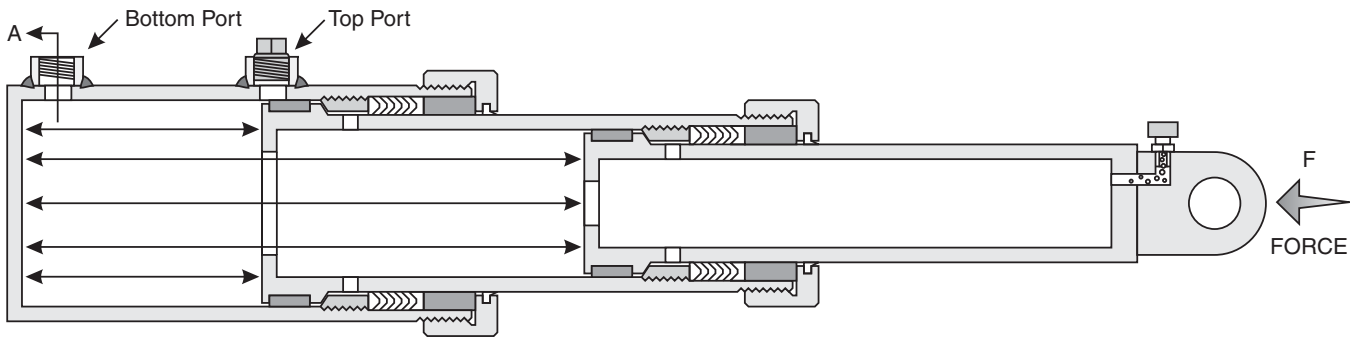

To Retract:

A single acting cylinder must be retracted by gravity or mechanical means (F).

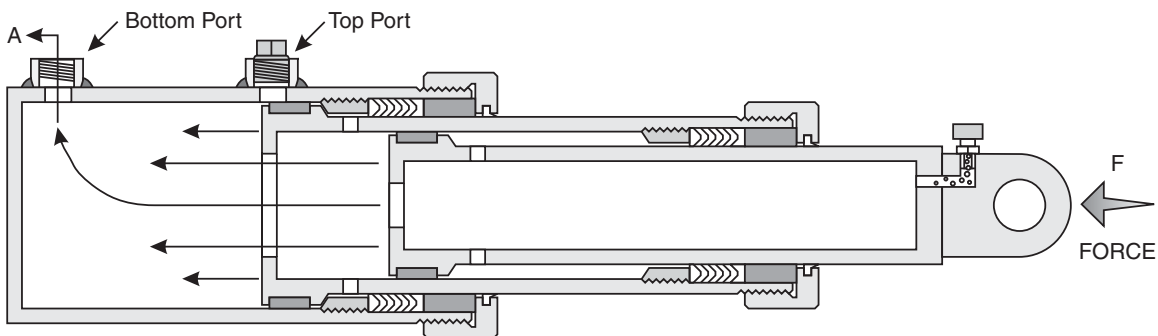

Under normal operating conditions the plunger or smallest diameter sleeve is pushed closed first, forcing oil out through port (A), then the next smallest, etc.

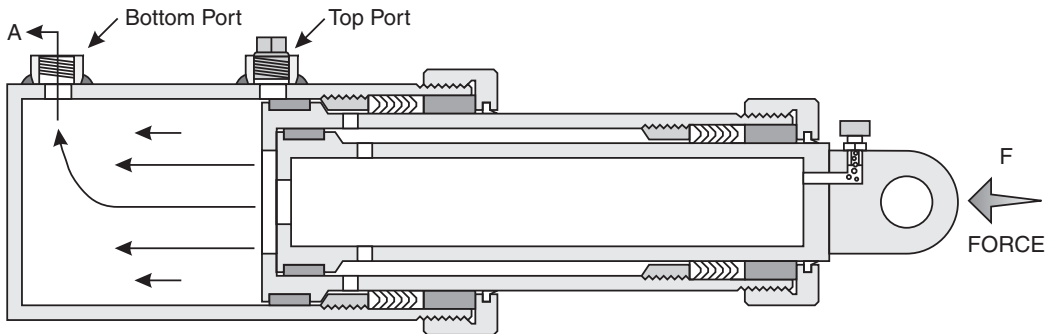

Note: If the top port is used, the speed of the cylinder may be reduced because of the oil flow restriction as the oil passes thru the transfer holes (G).

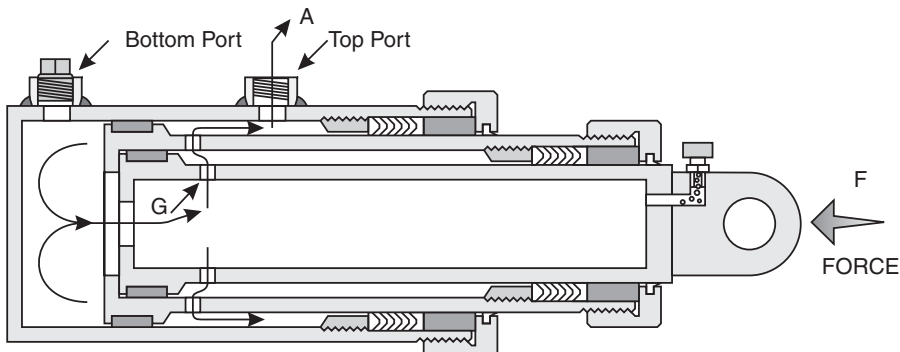

Equip your vehicle with
 **Commercial Hydraulics**
the world's best hydraulic cylinders

Double Acting Telescopic Cylinder Operation

Extending

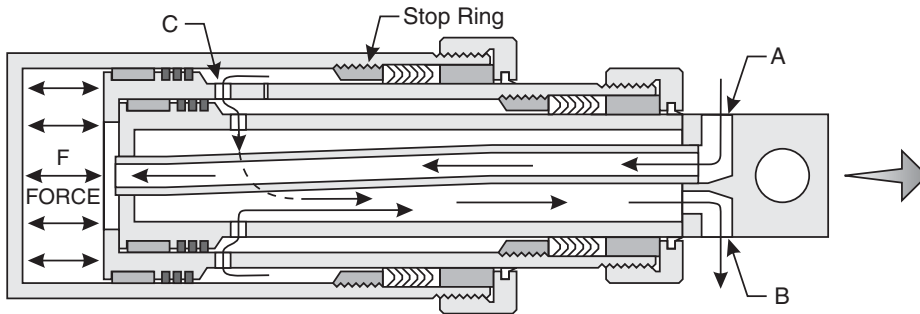

To Extend:

High pressure oil is directed by the control valve into port A. The oil passes through the transfer tube in the rod to the base of the cylinder.

The pressure acts on the effective area (area of the largest piston) and extends all stages to the first stop ring. The next stage then begins to extend.

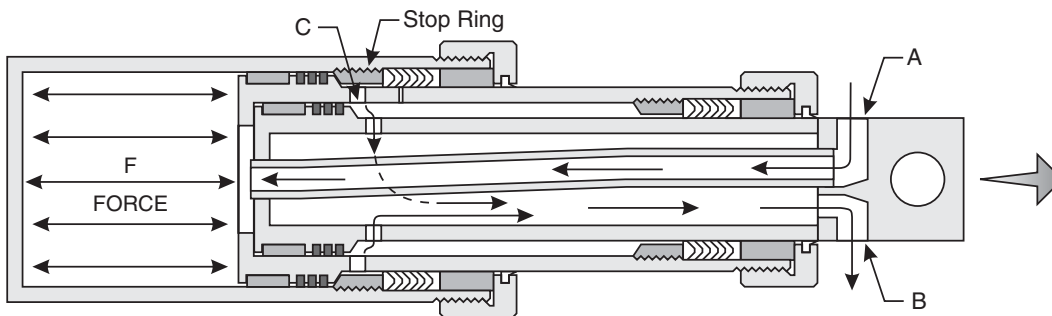

The effective area of each stage is figured from the inside diameter of the next largest stage. Each stage extends in its turn to the stop ring. So at a given PSI (pressure) and GPM (gallons per min.) the cylinder will develop less force and increase in speed as it changes to the next moving stage.

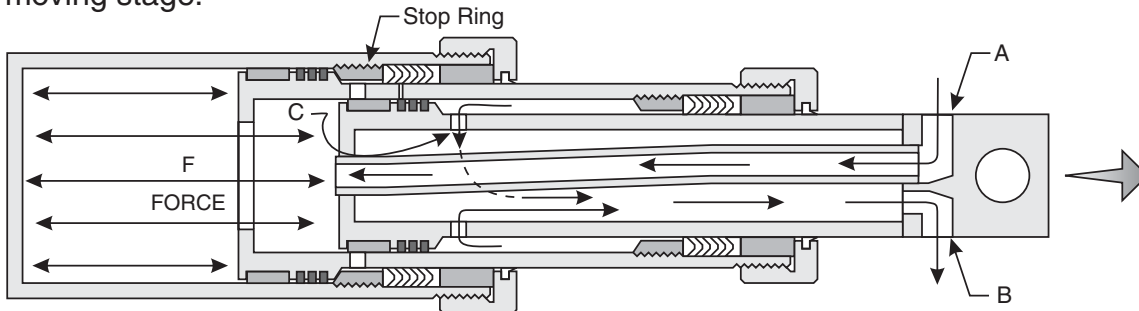

Oil trapped between the sleeves escapes through holes (C) in each sleeve and returns to the tank through port B.

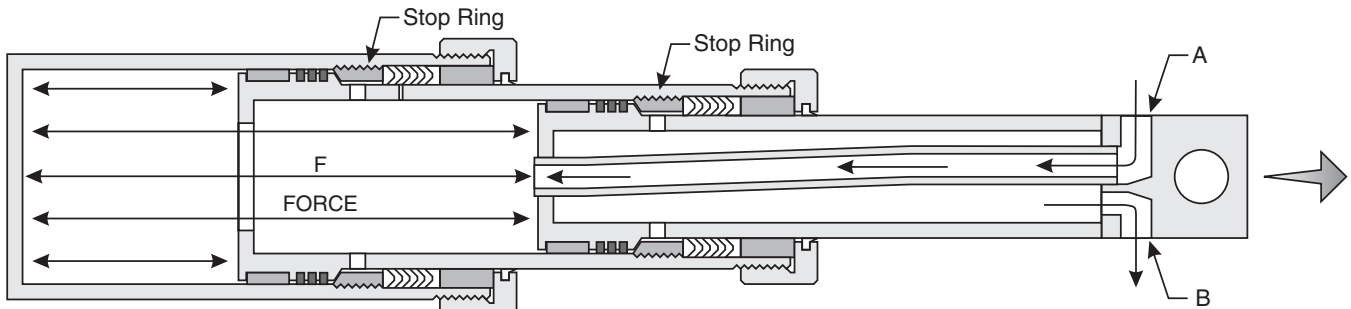

Double Acting Telescopic Cylinder Operation

Retracting

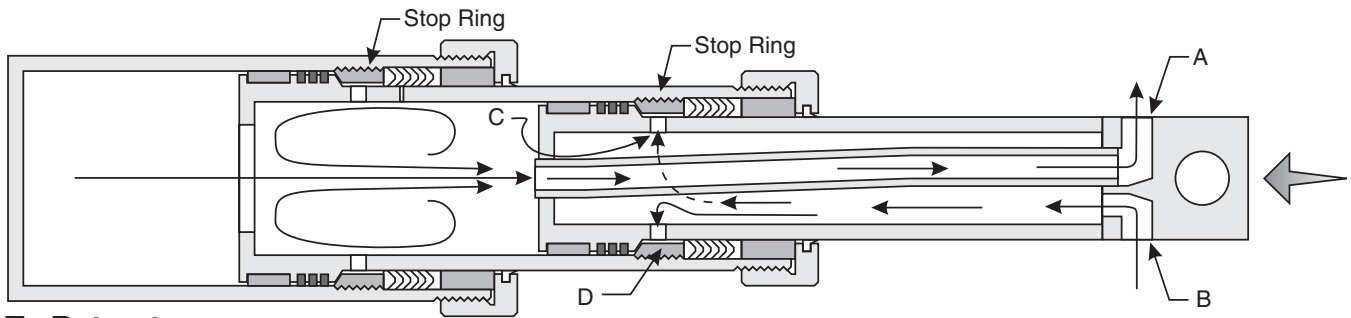

To Retract:

High pressure oil is directed by the control valve into port B. The pressure is applied to the effective area (D) of the plunger which retracts first. Each stage from the smallest to the largest

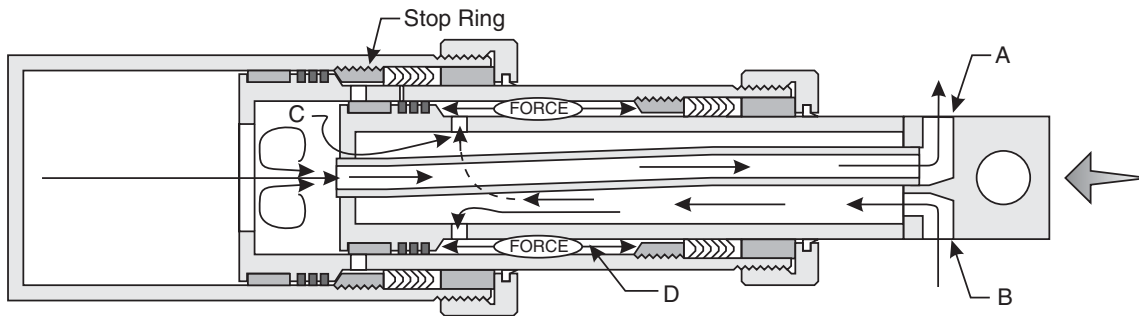

retracts in its turn, however, THE EFFECTIVE AREA FOR RETRACTING EACH STAGE IS THE AREA (D) OF THE PLUNGER.

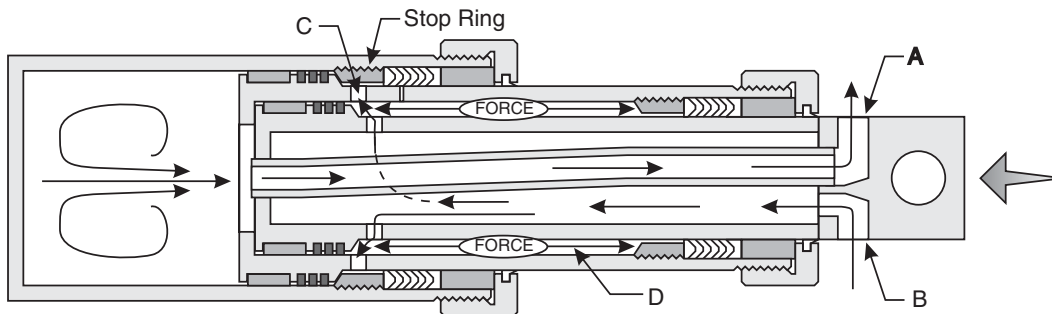

Oil inside the cylinder is forced out of port A. Because of the area differential, the flow into port B must be multiplied by this differential to determine the flow out of port A. It may be necessary to install a dump-to-tank valve to speed up the retracting cycle.

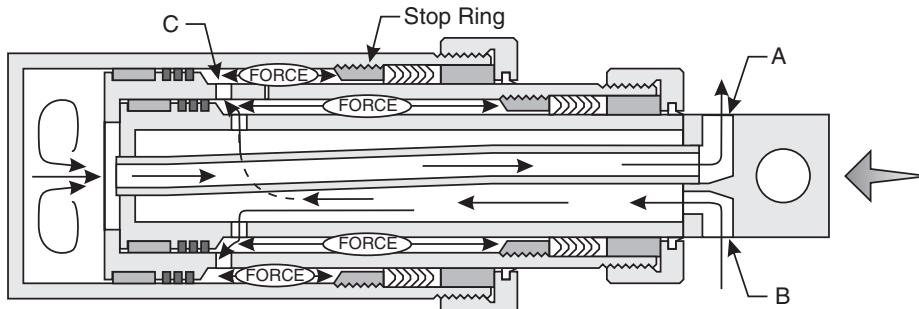

Equip your vehicle with
Commercial Hydraulics
 the world's best hydraulic cylinders

1) Function Test

Once the Cylinder is placed on the test stand and hydraulic lines attached, the cylinder will be cycled its full stroke a minimum of three (3) full cycles.

The cylinder will be rejected if it functions erratically. Erratic function is excessive chatter, slapstrick, stalling and uncorrectable misstaging.

2) Proof Pressure Test

After the function test is performed the cylinder will be extended fully and pressure held for a minimum of thirty (30) seconds. This pressure will be 2500 psi or a pressure indicated on the assembly print. The cylinder will be rejected for external leakage or structural deformation. If the cylinder is double acting, it will be fully retracted and pressure held for a minimum of thirty (30) seconds. The pressure will be 2500 psi or a pressure indicated on the assembly print. The cylinder will be rejected for external leakage or structural deformation.

3) Internal Bypass Test

This test will be performed on all double acting cylinders and can be done in conjunction with the Proof Pressure Test. The cylinder will be fully extended and pressure held at 2500 psi. The retract line will be removed and piston seal bypass will be determined by the flow out of this cylinder port. Excessive bypass will be a cause for cylinder rejection. The cylinder will be fully retracted and pressure held at 2500 psi. The extend line will be removed and the piston bypass will be determined by the flow out of this cylinder port. The cylinder will be rejected for excessive flow. When making this test the hydraulic line should be completely removed from the cylinder port, and the open line from the valve should be plugged or capped since a slight back pressure in the tank return line would spill oil from the line if not plugged.

Pass/Fail criteria if not noted on Assembly drawing is as follows:

Cast Iron Rings Normal Maximum leakage 1 GPM.

Bypass = 1/2 cubic inch per inch of bore diameter per minute.

Extend bypass would be 1/2 cubic inch per inch of plunger piston ring OD per minute.

Retract bypass would be 1/2 cubic inch per inch of piston ring OD per minute of each stage added together.

Example SD73 Series;

Extend bypass; $1/2 \times 5.25 = 2.62$ cubic in / min.

Retract bypass; $(1/2 \times 7.25) + (1/2 \times 6.25) + (1/2 \times 5.25) = 9.38$ cubic in / min.

Soft Seals Maximum leakage 5 drops per minute.

Please Note

Before Installing a New Cylinder in an old application

Has the problem been corrected that caused the original cylinder to fail?

Is the hydraulic fluid clean of all contamination, water, and entrapped air?

Are the hydraulic system relief valve pressures set and operating properly?

Is the mechanism or unit the cylinder is operating in good mechanical condition?

Storage and Installation

STORAGE

It pays to keep spare hydraulic cylinders on hand for use when you need them. But, you must know and follow these recommended storage practices or the cylinders can be ruined. Hydraulic cylinders, though often large and unwieldy, are precision machines with finely finished parts and close tolerances. And they're expensive. So handle them with care.

For optimum storage life, hydraulic cylinders should be kept in an environment that is protected from excessive moisture and temperature extremes. A hot, dry desert climate with cold nights, for example, must be accommodated when choosing the storage area. Daytime heat quickly bakes oil out of sealing materials, which causes leaks and rapid wear when the cylinder is placed in service. Cooling at night causes water condensation and corrosion damage to wear surfaces. Storage areas that allow exposure to rain, snow and extreme cold must like wise be avoided.

It's best to store cylinders indoors if possible. But indoors or out, be sure that plugs or closures are properly installed in all ports to keep out moisture and dirt. However, overtightening of port plugs should be avoided. Widely varying temperatures and tightly closed ports may cause pressure inside the cylinder to build up to the point where the piston moves far enough to expose the rod to corrosion or contamination. Try to choose a storage location where the cylinders are protected from physical damage. Even a little ding from a falling bar or forklift tine can cause trouble later.

Cylinders, Particularly large ones, should be stored closed in a vertical position with the rod end down. Be sure they're blocked securely to keep them from toppling. Storing with the rod ends down keeps oil on the seals, which protects them from drying out. This is more critical with fabric and butyl seals than with urethane sealing materials. Storing single-acting cylinders with the rod end up can cause port closures to pop open and leak, exposing the sleeves to corrosion damage and contamination. Storing with the rod end down also discourages the temptation to lift a cylinder by the rod eye – a dangerous practice. If horizontal storage cannot be avoided, the rod or cylinder should be rolled into a new position every two months or so to prevent drying, distortion and deterioration of the seals. Don't forget that a cylinder can be a major source of contamination. A small scratch or nick on the sleeve will quickly shred packing and contaminate the system. Store cylinders carefully and keep them clean.

The following procedures should be followed in order to prevent oxidation and maintain the surfaces of a mounted hydraulic cylinder during idle periods. These idle periods may include; inventory units, demo units, out of service units, etc.

- All machined surfaces left expose should be coated with a light film of grease, if not oxidation will occur.
- If oxidation is present, apply a light coat of oil to the surfaces.
- Buff surfaces with 320 or 400 grit sandpaper. Do not buff surfaces up and down the length, buff only around the circumference.
- If after buffing, the surfaces show evidence of oxidation damage i.e., pitting, the cylinder should be inspected by an authorized service center for evaluation.
- Operation of a hydraulic cylinder with surface damage will shorten the longevity and preclude any warranty express or implied.

INSTALLATION

- Cleanliness is an important consideration, and Parker cylinders are shipped with the ports plugged to protect them from contaminants entering the ports. These plugs should not be removed until the piping is to be installed. Before making the connection to the cylinder ports, the piping should be thoroughly cleaned to remove all chips or burrs which might have resulted from threading or flaring operations. One small foreign particle can cause premature failure of the cylinder or other hydraulic system components. If oxidation is present, apply a light coat of oil to the surfaces.
- Proper alignment of the cylinder piston rod and its mating component on the machine should be checked in both the extended and retracted positions. Improper alignment will result in excessive rod gland and/or cylinder bore wear.
- Cylinders operating in an environment where air drying material are present such as fast- drying chemicals, paint, or welding splatter, or other hazardous conditions such as excessive heat, should have shields installed to prevent damage to the piston rod and piston rod seals.

Bleederless Telescopic Cylinders

Innovative Mobile Solutions From
Mobile Cylinder Division



Customer Unmet Need:

Bleeding cylinders is a tough dirty job for the dump truck and trailer industry. No one really wants to bleed the cylinder because it is a dirty, dangerous, and environmentally hazardous job as the mechanic must climb in and out of the dump bed to adjust the bleeder screw. Failure to bleed the cylinder will result in early cylinder failure in addition to cylinder mis-staging, and excessive costly hydraulic repairs.

Solution:

Parker has developed a special bleed system that is incorporated into the cylinder that allows air to bleed every time the dump bed goes up and down. This keeps the cylinder free of air and as a result the bleeding of oil and air is eliminated.



Contact Information:

Parker Hannifin Corporation
Mobile Cylinder Division
1775 Logan Avenue
Youngstown, Ohio 44505

phone 800 848 5575
fax 800 694 3392
mcdsales@parker.com

www.parker.com

HY18-0027/US

Value Added:

- Fleets using Parker's high quality cylinders will benefit by saving the labor charges from bleeding cylinders through out the life time of the Dump Bed \$800-\$2400.
- OEM's save a minimum of 1/2 gallon of hydraulic oil to 4.5 gallons of oil on 8" and 9" cylinders. For a trailer manufacturer selling 500 a year this would save \$23,625 a year.

Product Features:

- No air to bleed
- No speedy dry to sweep
- No EPA to deal with
- No more climbing into dirty beds
- Fewer hydraulic repairs
- Completely interchangeable with all manufacturers cylinders
- Size Range from 4" to the largest 9" cylinders
- Reduced weight over standard cylinders with bleeder screws



ENGINEERING YOUR SUCCESS.

PARKER

Bleederless Design Cylinder

Air Purging Procedure

- 1. This cylinder is designed to automatically purge any trapped air from installation.**
- 2. Once the cylinder is mounted to the vehicle and the hydraulic system is connected, purge the air by cycling the cylinder to full extension 2-3 times.**
- 3. If air is still present as noted by the cylinder exhibiting a mushy, erratic bouncing action, repeat the cycling of the cylinder to full extension 2-3 times.**
- 4. If the condition continues, check all hydraulic connections for tightness before repeating.**
- 5. Contact Parker Customer Service @ 330-480-8431, 800-848-5575 if problem persists.**

375 9078 086



Hydraulic Oil Recommendations

All cylinder parts, with the exception of a few items, are lubricated by the hydraulic oil in the circuit. Particular attention must be paid to keep the oil in the circuit clean. Whenever there is a hydraulic component failure (cylinder, pump, valve), and there is a reason to feel that metal particles may be in the system, the oil must be drained, the entire system flushed clean, and any filter screens thoroughly cleaned or replaced. New oil should be supplied for the entire system. Oil suitable and recommended for use in circuits involving Commercial cylinders should meet the following specifications:

***These suggestions are intended as a guide only.
Obtain your final oil recommendations from your oil supplier.***

Viscosity Recommendations:

Optimum operating viscosity is considered to be about 100 SSU.

- * 50 SSU minimum @ operating temperature
7500 SSU maximum @ starting temperature
- * 150 to 225 SSU @ 100° F. (37.8° C.) (generally)
44 to 48 SSU @ 210° F. (98.9° C.) (generally)

Other Desirable Properties:

Viscosity Index: 90 minimum
Aniline point: 175 minimum

Additives Usually Recommended:

Rust and Oxidation (R & O) Inhibitors
Foam Depressant

Other Desirable Characteristics:

Stability of physical and chemical characteristics.
High demulsibility (low emulsibility) for separation of water, air and contaminants.
Resistant to the formation of gums, sludges, acids, tars and varnishes.
High lubricity and film strength.

General Recommendations:

A good quality hydraulic oil conforming to the characteristics listed above is essential to the satisfactory performance and long life of any hydraulic system.

Oil should be changed on regular schedules in accordance with the manufactures recommendations and the system periodically flushed.

Oil operating temperature should not exceed 200° F. (93° C.) with a maximum of 180° F. (82° C.) generally recommended. 120° F. to 140° F. (50° C. to 60° C.) is generally considered optimum. High temperatures result in rapid oil deterioration and may point out a need for an oil cooler or a larger reservoir. The nearer to optimum temperature, the longer the service life of the oil and the hydraulic components.

Reservoir size should be large enough to hold and cool all the fluid a system will need, yet it should not be wastefully large. Minimum required capacity can vary anywhere between 1 and 3 times pump output. The reservoir must be able to hold all of the fluid displaced by retracted cylinders when the system is not operating, yet provide space for expansion and foaming.

Oil poured into the reservoir should pass through a 100 mesh screen. Pour only clean oil from clean containers into the reservoir.

Never use Crank Case Drainings, Kerosene, Fuel Oil, or any Non-Lubricating Fluid, such as Water.

Approximate SSU at . . .

Oil Grade	100° F. (37.8° C.)	210° F. (98.9° C.)
SAE 10	150	43
SAE 20	330	51

Normal Temperatures:

0° F. (-18° C.) to 100° F. (37.8° C.) ambient
100° F. (37.8° C.) to 180° F. (82.2° C.) system

Be sure the oil you use is recommended for the temperature you expect to encounter.

System Inoperative:

- 1. Insufficient or No fluid in system.**

Refill system with proper grade and type of fluid.
Filter new oil being added as recommended.
Refill oil reservoir with cylinders in closed position.
If refilled while cylinders are extended the reservoir may over flow when or as the cylinders retract.
Check for leaks.
- 2. Pump is not engaged.**

Is pump shaft turning?
Check if PTO (power take off) is engaged.
Variable control mechanism out of adjustment.
Adjust to machine service manual specifications.
- 3. Slipping or broken pump drive.**

Check pump drive mechanism (drive key, flex coupler) for damage.
Check for proper alignment or tension.
- 4. Pump inlet line plugged.**

Drain oil and replace filter or filter element.
Check for clogged oil strainers.
Oil lines dirty or collapsed.
Check if correct inlet hose is used, inner liner may be collapsed.
Never use a pressure type hose as a pump inlet suction hose.
Check if supply shut off or gate valve is closed.
Check in reservoir for other possible obstructions.
- 5. Pump speed too slow.**

Check minimum drive speed.
May be too slow to prime pump.
- 6. Wrong fluid in system.**

Oil viscosity too heavy for pump to pick up a prime.
Drain complete system. Add new fluid of proper viscosity.
- 7. Air leaks at intake. Pump not priming.**

Circuit must be tested at inlet connections.
At pump intake piping joints, test by pouring oil on joints while listening for a change in sound of operation.
Determine where air is being drawn into line connection and tighten.
At pump shaft, Test by pouring oil on shaft seal while listening for a change in sound of operation.
Follow manufacturer's recommendation when changing seals.
Air drawn in through intake pipe opening.
Check to be certain suction and return lines are well below oil level in reservoir. Add oil to reservoir if necessary.
- 7. Worn or dirty pump.**

Clean, repair or replace.
Check alignment.
Check for contaminated oil.
Drain and flush system.
- 8. Pump driven in wrong direction of rotation.**

Most pump assemblies will have an arrow showing correct rotation.
On gear type pumps, the pressure port / output will be on the side where the gears come together and mesh.
Check to assure correct pump rotation was applied during assembly.
- 9. Leakage.**

Check all components, particularly the relief valve for proper settings.
Refer to technical manuals.

- 10. Broken or badly worn components (pump, valves, cylinders, etc.).**

Examine and test for internal or external leakage.
Analyze the conditions that brought on the failure and correct them.
Repair or replace the faulty components according to technical manual specifications.
- 11. Excessive load.**

Check unit specifications for load limits.

System Develops No Pressure:

- 1. Pump not delivering fluid.**

Follow the remedies mentioned above.
- 2. Incorrect valve position or setting.**

Check and engage valve.
Install pressure gauge and adjust to correct pressure.
- 3. Vanes in vane pump sticking.**

Check for burrs or metal particles that might hold vanes in their slots.
Repair or replace if necessary.
Clean system if contaminants are found.
- 4. Fluid recirculating back to reservoir and not going to functions.**

Mechanical failure of some other part of the system, especially a relief valve.
If contamination is involved, clean and refill with proper fluid.
- 5. Piston pump or valve broken, or stuck open allowing fluid to return to inlet side.**

Disassemble the pump, determine the cause and correct it.
Repair according to technical manual instructions.

System Operates Erratically:

- 1. Air in system.**

Check suction side for leaks. Repair.
- 2. Cold oil.**

Allow ample warm-up period.
Operate only at recommended operating temperature ranges.
- 3. Wrong fluid viscosity.**

Oil viscosity too heavy.
Drain complete system. Add new fluid of proper viscosity.
- 4. Pump speed too slow.**

Increase engine speed.
Check manual for recommendations.
- 5. Dirty or damaged components.**

Clean or repair as necessary.
- 6. Restriction in filters or lines.**

Clean and/or replace elements or lines.
- 7. Internal pump parts are sticking.**

Dismantle and repair according to technical manual instructions.
Look for burrs on parts or metal particles in fluid.
If contaminants are the cause, clean and refill with proper fluid.
- 8. Distance between internal parts has increased due to wear.**

Dismantle and repair.
If wear is abnormal, determine the cause by checking the operation and maintenance records as well as by examining the pump and system.

Troubleshooting Hints

System Operates Slowly:

- 1. Oil viscosity too high, cold oil.**
Allow oil to warm up before operating machine.
- 2. Low pump drive speed.**
Increase engine speed (check manual for recommendations).
If clutch or belt-driven, check for proper tension.
- 3. Low oil level.**
Check reservoir and add oil as necessary.
- 4. Air in system.**
Check suction side for leaks. repair.
- 5. Badly worn pump, valves, cylinders, etc.**
Repair or replace as needed.
- 6. Restriction in filters or lines.**
Clean and/or replace elements or lines.
- 7. Improper adjustments.**
Check orifices, relief, unloading, flow control valve etc.
Adjust per manual.
- 8. Oil leaks.**
Tighten fittings, replace seals or damaged lines.

System Operates Too Fast:

- 1. Wrong size or incorrectly adjusted restrictor or flow control.**
Replace or adjust as necessary.
- 2. Engine running too fast.**
Reduce engine speed.

Overheating of Oil in System:

- 1. Oil passing thru relief valve for excessive time.**
Return control valve to neutral when not in use.
System stalling under load, etc.
Fluid viscosity too high.
- 2. Relief or unloading valve set too high.**
Install pressure gauge and adjust to correct pressure.
- 3. Incorrect oil, low oil, dirty oil.**
Use recommended oil, fill reservoir, clean oil, replace filter element.
- 4. Engine running too fast.**
Reduce engine speed.
- 5. Excessive component internal leakage.**
Check stall leakage past pump, valve, motor, cylinder or other components.
Repair or replace component as necessary.
- 6. Restriction in filters or lines.**
Check if line I.D.'s are too small causing high velocity.
Check if valvings too small, causing high velocity.
Clean and/or replace elements or lines.
- 7. Malfunctioning oil cooler / heat exchanger.**
Check if water is shut off, if water cooled.
Check for clogging.
Clean repair.
- 8. Insufficient heat radiation.**
Check for proper air circulation around reservoir.
Ambient temperature too high for system design.
Clean dirt and mud from reservoir and components.
- 9. Reservoir sized too small.**
Increase reservoir size.
Add oil cooler or heat exchanger.
- 10. Reservoir assembled without or insufficient baffling.**
Add baffling to allow fluid time to cool.

Foaming of Oil:

- 1. Incorrect oil, low oil, dirty oil.**
Replace, clean or add as needed.
- 2. Air leaks.**
Check suction line and component seals for suction leaks. Repair or replace.
- 3. Return of tank line not below fluid level.**
Repair or replace.
- 4. Inadequate baffles in reservoir.**
- 5. Lack of anti-foaming additives in oil.**
Replace fluid with proper grade.

Noisy Pump:

- 1. Air leak in intake, or air is being drawn through the inlet line.**
Repair or make sure the inlet line is submerged in fluid in the reservoir.
To check for leaks, pour fluid around the joints and listen for a change in sound of operation.
- 2. Low oil level, incorrect oil, foamy oil.**
Check if oil viscosity too high or operating temperature too low.
Replace, clean or add proper grade and type of fluid as needed.
With rare exception all return lines should be below fluid level in reservoir
- 3. Pump inlet line or inlet screen is restricted or clogged.**
Clean or replace as needed.
- 4. Reservoir breather vent clogged.**
Clean or replace as needed.
- 5. Worn or damaged pump.**
Check and correct cause of parts failure.
Repair or replace as needed.
- 6. Pump speed too fast.**
Operate pump within recommended speed.
- 7. Drive coupling mis-aligned.**
Align unit and check condition of seals and bearings.
Misalignment will cause wear and subsequent high noise level in operation.
- 8. Relief or unloading valve set too high.**
Use reliable gauge to check operating pressure.
Relief valve may have been set too high with a damaged pressure gauge.
Check unloading devices to see that they are properly controlling the pump delivery.

Excessive Pump Wear:

- 1. Abrasive contaminants or sludge in the fluid.**
Check for the cause of contaminants.
Replace or repair worn parts according to service manual.
Install or change fluid filter.
Replace fluid with recommended grade and quality.
- 2. Viscosity of fluid too low or too high.**
Replace fluid with proper grade and type.
- 3. Sustained high pressure above maximum pump rating.**
Check for possible relief valve malfunction or other parts failure.
- 4. Air leaks or restriction in system causing cavitation.**
Eliminate any leaks in system.
- 5. Drive shaft misaligned.**
Check and correct according to technical manual specifications.

Troubleshooting Hints

Leaky Pump or Motor:

- 1. Damaged or worn shaft seal.**
Check and replace.
Check for misalignment.
Check that chemicals in fluid are not destroying packing or seals
- 2. Loose or damaged parts.**
Tighten or replace.

Internal Pump Parts Breakage:

- 1. Excessive pressure above maximum limits for pump.**
Check for parts malfunction and cause.
Repair according to machine technical manual.
- 2. Seizure due to lack of fluid.**
Check reservoir fluid level, as well as fluid inlet line for restriction.
Check for plugged inlet filter or strainer.
- 3. Abrasive contaminants in fluid are getting past the filter.**
Check for plugged inlet filter or strainer.
Check for malfunctioning filter bypass valve.
- 4. Excessive torquing of housing bolts.**
Replace damaged parts.
Torque to proper specifications.

Load Drops with Control Valve in Neutral:

- 1. Leaking cylinder seals or fittings.**
Replace worn parts.
- 2. Control valve not centering when released.**
Check linkage.
Check spool for binding.

Control Valve Sticking (Binding):

- 1. Valve linkage misaligned.**
Repair.
- 2. Tie-bolts too tight (stack valves).**
Loosen and retighten as necessary.
- 3. Valve damaged.**
Repair or replace.

Control Valve Leaks:

- 1. Tie-bolts too loose (stack valves).**
Tighten as necessary.
- 2. Seals damaged or worn.**
Replace.

Relief Valve Noisy:

- 1. Relief valve setting too close to operating pressure.**
Install pressure gauge and adjust to correct pressure.
- 2. Worn or scored poppet and seat.**
Replace.
- 3. Spring in relief valve broken.**
Replace spring and adjust to correct pressure.

Cylinder Seal Leakage:

- 1. Slow, Uniform Leakage:**
 - A. Poor low-pressure sealability (especially if a lip seal).
 - B. Too little initial interference (if squeeze-type seal).
 - C. Loss of interference or squeeze due to wear or compression set.
 - D. Seal shrinkage after installation (possibly chemically induced, or a result of leaching of plasticizers by solvent action).
 - E. Possible omission or failure of static seal(s).
 - F. Microscopic debris lodges under seal lip (lint, fiber, etc.).
 - G. Scored lip due to passage of sharp particle under seal, leaving cut or nick.

- H. Seal lip is nicked or cut during installation (note whether leak starts immediately after seal installation).
- I. Non-repetitive overheating hardens compound (which loses its ability to conform to dynamic surface deviations).
- J. Off-center alignment puts all clearance on one side, all compression on the other (due to bearing wear, excessive side loads, etc.).
- K. Check *static* surfaces of dynamic seal (groove surfaces). They may have problems F, G, or H hidden from view, and without self-cleaning tendency.

2. Gradually Increasing Leakage:

- A. Progressive wear.
- B. Increasing compression set.
- C. Progressive tear or erosion from initial nick.
- D. Fine score mark on dynamic surface progressively abrades seal lip.

3. Sudden Copious Leakage:

- A. Extruded seal.
- B. Torn seal lip (see 1-D, -E, -F, -G, -H, & -I, and 2-D).
- C. Twisted seal.
- D. Dramatic bearing failure due to excessive side load, shock, etc.
- E. Spiral failure.
- F. Massive infusion of contamination (due to incorrect fluid added to system, or to upstream introduction of dirt or wear debris).

- G. Slow rod leakage builds up behind tight wiper, then dumps . . . giving *appearance* of catastrophic seal failure. If leak rate continues, look for slow leak or erratic leak causes. If high leak rate continues, look for true catastrophic leak origin.
- H. Reverse-pressure blowout of piston seal due to pressure trap or failure of opposed seal.

4. Erratic (start-stop) Leakage:

- A. Cold start-up shrinks seal; friction/fluid heating restores size.
- B. Intermittent eccentric loading.
- C. Fibrous contamination working its way past seal lips.
- D. Unstable seal (twists and returns, cocks, etc.) *usually* caused by shock loading.
- E. Rod seal leaks slowly, tight wiper periodically dumps accumulated leakage (see 3-G).
- F. Fluid viscosity changes as temperature cycles (e.g., forklift truck alternately entering and leaving cold storage area).

5. Stick-slip Operation:

- A. Worn-away, low friction surface treatment.
- B. Breakdown of fluid lubricity due to contamination or deterioration of fluid.
- C. Viscosity change due to temperature.
- D. Excessive burnishing of dynamic surface to finer finish destroys ability of surface to maintain lube film (e.g., may go from 12 RMS to 4 RMS).

6. Seizing:

- A. Seal and bearing swell due to incompatible fluid and compound (possibly running hotter than temperature at which fluid is compatible).
- B. Thermal expansion of compound.
- C. Pressure trap between dual squeeze seals or incorrectly installed lip seals.
- D. Wedging of seal or backup device into extrusion gap (if used, it is usually the backup device that extrudes).

Troubleshooting Hints

- E. In low-pressure systems, shock or other factors cock, cant or misorient the seals in grooves.
- F. Bent rod, cocked head, etc.

7. Scored Rod or Ram:

- A. Internally generated contamination.
- B. Externally introduced rod dirt, dirty makeup or disassembly/ reassembly dirt.
- C. Misoriented exclusion devices (wiper/scrapper); eccentric installation.
- D. Misaligned (eccentric) loads cock ram into metal-to-metal contact with head.
- E. Wiper in vertical ram forms catch-all pocket.

8. Drift:

- A. Inspect valve for leakage and full closure *before* disassembly. (disconnect return line on valve and inspect visually for leakage).
- B. See problems 1 and 2 as applied to piston seals.
- C. Misapplied cast-iron rings in a "hold" cylinder (right ring in the wrong job).
- D. In "retract-mode" creep, check rod seal as well as piston seal.
- E. Static internal seal may provide leakage path past piston.

9. Increasing Cylinder Drag:

- A. Seal swell caused by improper (incompatible) *installation* lubricant (e.g., EPR seal lubed with petro-based grease or oil).
- B. Packing of contaminants into wiper groove of vertical ram.
- C. Thermal expansion of bearings and/or seals.
- D. Apparent drag increase due to undetected flow restriction in supply or return line . . . or bypassing of pressure though improperly closing valve . . . or obstructed check valve, etc.
- E. Cocked or twisted seal bypassing fluid and wedging into extrusion gap.

10. Increasing Cylinder/Rod Temperature:

- A. See causes for problem 9. In their earlier stages, these problems may appear as hotter-running cylinders.
- B. Internal leakage "throttling" past seal can cause rapid heating.
- C. Decreased lubricity of fluid can boost friction and heating (hotter fluid has lower viscosity, etc.). Contaminated or deteriorated fluid can cause same cycle.
- D. Diluted fluid can boost friction, etc.
- E. Condensation in reservoirs can emulsify or hit cylinder as slugs of fluid with near-zero lubricity. Also, hot water can *swell* compounds such as urethanes, increasing friction.

11. Telescopic sleeve undersized, out of round or bulged.

- A. Check with micrometers to see if sleeve/tube is within specifications.

Cylinder will not Operate or Move:

1. Pump or PTO is not engaged, system not receiving fluid.

Engage pump, correct pump flow problem.

2. Control valve not engaged.

Engage valve, check for linkage alignment and damage.

3. Pressure too low.

Check pressure at cylinder to make sure it is to circuit requirements.

4. Cylinder bypassing internally.

Check for internal scoring, damaged or worn seals,

internal cracks.

5. Cylinder overloaded for rated capacity.

Reduce load.

6. Cylinder too small or not rated for application.

Install correct cylinder.

7. Piston rod broken at piston end.

Disassemble and replace piston rod.

8. Hose quick disconnect not attached.

Check if hose quick disconnect is connected properly.

Cylinder not Holding Load or Drifts:

1. Cylinder bypassing internally.

Check for internal scoring, damaged or worn seals, internal cracks.

Pressurize one side of cylinder and disconnect fluid line at opposite port. Observe leakage. One to three cubic inches per minute is considered normal for piston rings. Virtually no leak with soft seals on piston. Replace cylinder barrel or seals as required.

2. Other circuit leaks.

Check for leaks thru operating valve and correct. Correct leaks in connecting lines.

3. Incorrect Valving.

Open center valve with conventional single rod cylinder will creep if restriction on tank port is sufficiently high. Use tandem type valve spool configuration or spool with pump dumped through one cylinder port with the other blocked.

Closed center valve can cause similar results except creep will be according to amount of clearance flow in the valve. Proper notching of valve spool can prevent building up pressure in cylinder lines between cycles.

Spools with pressure blocked and cylinder ports completely relaxed will also prevent drift if no moving element is not affected by gravity or vibration.

Pilot operated check valves can positively lock fluid in cylinder lines. Care must be exercised to insure adequate pilot pressure when rod differential may cause intensification.

Cylinder operates erratically or chatters:

1. Telescopic cylinder sleeves mistaging.

Check for tight seals or bearings.

2. Excessive friction due to damaged or improper / misaligned mounting.

Repair or replace as needed.

3. Cylinder sized too close to load requirements.

Reduce load or install larger cylinder.

4. Large difference between static and kinetic friction.

Install speed control valves to provide back pressure to control stroke.

Oil Spilling Out of Tank:

1. Oil is foaming.

(Refer to Foaming of Oil section)

2. Oil reservoir filled while cylinders were extended.

Fill while cylinders in the retract or closed position.

Foreign Matter Sources in the Circuit:

1. Pipe scale not properly removed.

Lines need cleaned and flushed before installation.

2. Sealing compound (pipe dope, teflon tape) allowed to get inside fittings.

Use care when applying sealants.

3. Improperly screened fill pipes and air breathers.

Repair or replace as required.

Troubleshooting Hints

4. **Burrs inside piping components.**
Deburr before installation.
5. **Tag ends of packing coming loose.**
Check if packing is system compatible.
Replace packing.
6. **Seal extrusions from pressure higher than compatible with the seal or gasket.**
Replace seal or gasket with compatible item.
7. **Human element.**
Not protecting components while being repaired.
Repaired components not properly protected while stored. (Rust and other contaminants.)
Lines left open and unprotected.
8. **Wipers or boots damage or not provided.**
Check cylinders or rams.
Add or replace where necessary.

Preventing repeat failures:

When a hydraulic system (pump or cylinder or other major component) has a failure, implementing this 13-step checklist can help prevent repeat failures.

1. Determine cause of failure.
2. Eliminate cause of failure.
3. Retract all cylinders and drain tank.
4. Flush tank. Using diesel fuel under pressure, flush tank thoroughly and wipe with clean cloths.
5. Install new filter elements.
 - A. Check to make sure filter is 10 microns or better.
 - B. If machine does not have filtration, install a 10 micron filter on the return line.
6. Install new component.
7. Fill the tank with new oil.
 - A. Be sure recommended oil is used.
 - B. NOTE; You're filling the system, not just the oil supply tank. Pump failure due to lack of oil can result if filling is not done correctly.
Keep a close check on the oil level as you complete the following steps.
8. Disconnect all lines to cylinders and/or motors at the cylinder or motor. Be sure all implements are securely blocked and all accumulators are bled before disconnecting lines. NOTE; It may be necessary to remove, inspect, and flush the fittings that are connected to the pump, valves, and/or cylinders to remove any foreign objects that may have become lodged or stuck inside them.
9. Activate each circuit by moving control valve handle so lines are flushed with new oil. This flushes the lines and valves from pump to all cylinders and motors. Be sure to check oil level, and add new oil if necessary.
10. Connect lines to blind end of cylinders and all fluid motors. Leave rod end disconnected and with engine at one-fourth throttle, activate circuits slowly until cylinder bottoms out. New oil will be put in the blind end of the cylinder and old dirty oil flushed out the rod end. Do this for all cylinders on the machine.

11. Connect lines to rod end of cylinders. Again, check oil level and add new oil as required.
12. Operate all cylinders and motors alternately for 30 minutes at normal operating speed.
13. Change filter element, check oil level and add oil as needed.

The above procedure, if followed, will allow you to install a new pump or cylinder with confidence, knowing that you'll get satisfactory life. Cutting short these steps can cause premature hydraulic component failure; a pump, nor a cylinder will run long on a contaminated system. In nearly all cases, a replacement component will fail in a shorter time than the original preceding it unless the system is thoroughly cleaned.

In addition, to ensure good service from your equipment, the hydraulic system must be properly maintained, including frequent oil level checks, daily inspection for leaks, filter element and oil changes at recommended intervals (using correct filters and recommended grade of oil), and finally, practicing good operating techniques.

Parker Safety Guide for Selecting and Using Hydraulic Cylinders and Their Accessories

WARNING:  FAILURE OR IMPROPER SELECTION OR IMPROPER USE OF CYLINDERS AND THEIR RELATED ACCESSORIES CAN CAUSE DEATH, PERSONAL INJURY AND PROPERTY DAMAGE.

Before selecting or using Parker cylinders or related accessories, it is important that you read, understand and follow the following safety information.

User Responsibility

Due to very wide variety of cylinder applications and cylinder operating conditions, Parker does not warrant that any particular cylinder is suitable for any specific application. This safety guide does not analyze all technical parameters that must be considered in selecting a product. The hydraulic and pneumatic cylinders outlined in this catalog are designed to Parker's design guide lines and do not necessarily meet the design guide lines of other agencies such as American Bureau of Shipping, ASME Pressure Vessel Code etc. The user, through its own analysis and testing, is solely responsible for:

- Making the final selection of the cylinders and related accessories.
- Determining if the cylinders are required to meet specific design requirements as required by the Agency(s) or industry standards covering the design of the user's equipment.
- Assuring that the user's requirements are met, OSHA requirements are met, and safety guidelines from the applicable agencies such as but not limited to ANSI are followed and that the use presents no health or safety hazards.
- Providing all appropriate health and safety warnings on the equipment on which the cylinders are used.

Seals

The seals for the product lines shown in this catalogue are intended for mineral base hydraulic fluids and for the operating temperatures ranges as indicated. The operation of these products with other fluids or at other operating temperatures must be brought to the attention of our engineering department so that proper seals for intended operation may be selected.

The application of cylinders may allow fluids such as cutting fluids, wash down fluids etc. to come in contact with the external area of the cylinder. These fluids may attack the piston rod wiper and or the primary seal and must be taken into account when selecting and specifying seal compounds.

Dynamic seals will wear. The rate of wear will depend on many operating factors. Wear can be rapid if a cylinder is mis-aligned or if the cylinder has been improperly serviced. The user must take seal wear into consideration in the application of cylinders.

Piston Rods

Possible consequences of piston rod failure or separation of the piston rod from the piston include, but are not limited to are:

- Piston rod and or attached load thrown off at high speed.
- High velocity fluid discharge.
- Piston rod extending when pressure is applied in the piston retract mode.

Piston rods or machine members attached to the piston rod may move suddenly and without warning as a consequence of other conditions occurring to the machine such as, but not limited to:

- Unexpected detachment of the machine member from the piston rod.
- Failure of the pressurized fluid delivery system (hoses, fittings, valves, pumps, compressors) which maintain cylinder position.
- Catastrophic cylinder seal failure leading to sudden loss of pressurized fluid.
- Failure of the machine control system.

Part of selecting cylinders for a specific operation involves the proper selection of the piston rod diameter. This catalogue contains informa-

tion in the selection of piston rod diameter, which must be followed in order to avoid possible buckling.

Piston rods are not normally designed to absorb bending moments or loads which are perpendicular to the axis of piston rod motion. These additional loads can cause the piston rod to fail. If these types of additional loads are expected to be imposed on the piston rod, their magnitude should be made known to our engineering department.

The cylinder user should always make sure that the piston rod is securely attached to the machine member.

Cushions

Cushions are devices internal to the cylinder to slow the piston and rod assembly down at the end of the stroke. It is suggested they be used to reduce piston impact at the end of the cylinder stroke when the cylinder is expected to move at relatively high velocity.

Cylinder cushions are normally designed to absorb the energy of a linear applied load. A rotating mass has considerably more energy than the same mass moving in a linear mode. Cushioning for a rotating mass application should be review by our engineering department.

Cylinder Mountings

Some cylinder mounting configurations may have certain limitations such as but not limited to minimum stroke for side or foot mounting cylinders or pressure de-ratings for certain flange mounts. Carefully review the catalog for these types of restrictions.

Always mount cylinders using the largest possible high tensile alloy steel socket head cap screws that can fit in the cylinder mounting holes and torque them to the manufacturer's recommendations for their size.

Port Fittings

Hydraulic cylinders applied with meter out or deceleration circuits are subject to intensified pressure at piston rod end.

The rod end pressure is approximately equal to:

$$\frac{\text{operating pressure} \times \text{effective cap end area}}{\text{effective rod end piston area}}$$

Contact your connector supplier for the pressure rating of individual connectors.

Cylinder Modifications or Repairs

Cylinders as shipped from the factory are not to be disassembled and or modified. If cylinders require modifications, these modifications must be done at Parker locations or by Parker certified facilities. The Mobile Cylinder Division Engineering Department must be notified in the event of a mechanical fracture or permanent deformation of any cylinder component (excluding seals). This includes a broken piston rod, mounting accessory or any other cylinder component. This notification should include all operation and application details. This information will be used to provide an engineered repair that will prevent recurrence of the failure. It is allowed to disassemble cylinders for the purpose of replacing seals or seal assemblies.

Offer of Sale

The items described in this document and other documents and descriptions provided by Parker Hannifin Corporation, its subsidiaries and its authorized distributors ("Seller") are hereby offered for sale at prices to be established by Seller. This offer and its acceptance by any customer ("Buyer") shall be governed by all of the following Terms and Conditions. Buyer's order for any item described in its document, when communicated to Seller verbally, or in writing, shall constitute acceptance of this offer. All goods or work described will be referred to as "Products".

- 1. Terms and Conditions.** Seller's willingness to offer Products, or accept an order for Products, to or from Buyer is expressly conditioned on Buyer's assent to these Terms and Conditions and to the terms and conditions found on-line at www.parker.com/saleterms/. Seller objects to any contrary or additional term or condition of Buyer's order or any other document issued by Buyer.
- 2. Price Adjustments; Payments.** Prices stated on the reverse side or preceding pages of this document are valid for 30 days. After 30 days, Seller may change prices to reflect any increase in its costs resulting from state, federal or local legislation, price increases from its suppliers, or any change in the rate, charge, or classification of any carrier. The prices stated on the reverse or preceding pages of this document do not include any sales, use, or other taxes unless so stated specifically. Unless otherwise specified by Seller, all prices are F.O.B. Seller's facility, and payment is due 30 days from the date of invoice. After 30 days, Buyer shall pay interest on any unpaid invoices at the rate of 1.5% per month or the maximum allowable rate under applicable law.
- 3. Delivery Dates; Title and Risk; Shipment.** All delivery dates are approximate and Seller shall not be responsible for any damages resulting from any delay. Regardless of the manner of shipment, title to any products and risk of loss or damage shall pass to Buyer upon tender to the carrier at Seller's facility (*i.e.*, when it's on the truck, it's yours). Unless otherwise stated, Seller may exercise its judgment in choosing the carrier and means of delivery. No deferment of shipment at Buyers' request beyond the respective dates indicated will be made except on terms that will indemnify, defend and hold Seller harmless against all loss and additional expense. Buyer shall be responsible for any additional shipping charges incurred by Seller due to Buyer's changes in shipping, product specifications or in accordance with Section 13, herein.
- 4. Warranty.** Seller warrants that the Products sold hereunder shall be free from defects in material or workmanship for a period of eighteen months from the date of delivery to Buyer. The prices charged for Seller's products are based upon the exclusive limited warranty stated above, and upon the following disclaimer: **DISCLAIMER OF WARRANTY: THIS WARRANTY COMPRISES THE SOLE AND ENTIRE WARRANTY PERTAINING TO PRODUCTS PROVIDED HEREUNDER. SELLER DISCLAIMS ALL OTHER WARRANTIES, EXPRESS AND IMPLIED, INCLUDING MERCHANTABILITY AND FITNESS FOR A PARTICULAR PURPOSE.**
- 5. Claims; Commencement of Actions.** Buyer shall promptly inspect all Products upon delivery. No claims for shortages will be allowed unless reported to the Seller within 10 days of delivery. No other claims against Seller will be allowed unless asserted in writing within 60 days after delivery or, in the case of an alleged breach of warranty, within 30 days after the date within the warranty period on which the defect is or should have been discovered by Buyer. Any action based upon breach of this agreement or upon any other claim arising out of this sale (other than an action by Seller for any amount due to Seller from Buyer) must be commenced within thirteen months from the date of tender of delivery by Seller or, for a cause of action based upon an alleged breach of warranty, within thirteen months from the date within the warranty period on which the defect is or should have been discovered by Buyer.
- 6. LIMITATION OF LIABILITY.** UPON NOTIFICATION, SELLER WILL, AT ITS OPTION, REPAIR OR REPLACE A DEFECTIVE PRODUCT, OR REFUND THE PURCHASE PRICE. IN NO EVENT SHALL SELLER BE LIABLE TO BUYER FOR ANY SPECIAL, INDIRECT, INCIDENTAL OR CONSEQUENTIAL DAMAGES ARISING OUT OF, OR AS THE RESULT OF, THE SALE, DELIVERY, NON-DELIVERY, SERVICING, USE OR LOSS OF USE OF THE PRODUCTS OR ANY PART THEREOF, OR FOR ANY CHARGES OR EXPENSES OF ANY NATURE INCURRED WITHOUT SELLER'S WRITTEN CONSENT, EVEN IF SELLER HAS BEEN NEGLIGENT, WHETHER IN CONTRACT, TORT OR OTHER LEGAL THEORY. IN NO EVENT SHALL SELLER'S LIABILITY UNDER ANY CLAIM MADE BY BUYER EXCEED THE PURCHASE PRICE OF THE PRODUCTS.
- 7. Contingencies.** Seller shall not be liable for any default or delay in performance if caused by circumstances beyond the reasonable control of Seller.
- 8. User Responsibility.** The user, through its own analysis and testing, is solely responsible for making the final selection of the system and Product and assuring that all performance, endurance, maintenance, safety and warning requirements of the application are met. The user must analyze all aspects of the application and follow applicable industry standards and Product information. If Seller provides Product or system options, the user is responsible for determining that such data and specifications are suitable and sufficient for all applications and reasonably foreseeable uses of the Products or systems.
- 9. Loss to Buyer's Property.** Any designs, tools, patterns, materials, drawings, confidential information or equipment furnished by Buyer or any other items which become Buyer's property, may be considered obsolete and may be destroyed by Seller after two consecutive years have elapsed without Buyer placing an order for the items which are manufactured using such property. Seller shall not be responsible for any loss or damage to such property while it is in Seller's possession or control.
- 10. Special Tooling.** A tooling charge may be imposed for any special tooling, including without limitation, dies, fixtures, molds and patterns, acquired to manufacture Products. Such special tooling shall be and remain Seller's property notwithstanding payment of any charges by Buyer. In no event will Buyer acquire any interest in apparatus belonging to Seller which is utilized in the manufacture of the Products, even if such apparatus has been specially converted or adapted for such manufacture and notwithstanding any charges paid by Buyer. Unless otherwise agreed, Seller shall have the right to alter, discard or otherwise dispose of any special tooling or other property in its sole discretion at any time.
- 11. Buyer's Obligation; Rights of Seller.** To secure payment of all sums due or otherwise, Seller shall retain a security interest in the goods delivered and this agreement shall be deemed a Security Agreement under the Uniform Commercial Code. Buyer authorizes Seller as its attorney to execute and file on Buyer's behalf all documents Seller deems necessary to perfect its security interest. Seller shall have a security interest in, and lien upon, any property of Buyer in Seller's possession as security for the payment of any amounts owed to Seller by Buyer.
- 12. Improper use and Indemnity.** Buyer shall indemnify, defend, and hold Seller harmless from any claim, liability, damages, lawsuits, and costs (including attorney fees), whether for personal injury, property damage, patent, trademark or copyright infringement or any other claim, brought by or incurred by Buyer, Buyer's employees, or any other person, arising out of: (a) improper selection, improper application or other misuse of Products purchased by Buyer from Seller; (b) any act or omission, negligent or otherwise, of Buyer; (c) Seller's use of patterns, plans, drawings, or specifications furnished by Buyer to manufacture Product; or (d) Buyer's failure to comply with these terms and conditions. Seller shall not indemnify Buyer under any circumstance except as otherwise provided.
- 13. Cancellations and Changes.** Orders shall not be subject to cancellation or change by Buyer for any reason, except with Seller's written consent and upon terms that will indemnify, defend and hold Seller harmless against all direct, incidental and consequential loss or damage. Seller may change product features, specifications, designs and availability with notice to Buyer.
- 14. Limitation on Assignment.** Buyer may not assign its rights or obligations under this agreement without the prior written consent of Seller.
- 15. Entire Agreement.** This agreement contains the entire agreement between the Buyer and Seller and constitutes the final, complete and exclusive expression of the terms of the agreement. All prior or contemporaneous written or oral agreements or negotiations with respect to the subject matter are herein merged.
- 16. Waiver and Severability.** Failure to enforce any provision of this agreement will not waive that provision nor will any such failure prejudice Seller's right to enforce that provision in the future. Invalidation of any provision of this agreement by legislation or other rule of law shall not invalidate any other provision herein. The remaining provisions of this agreement will remain in full force and effect.
- 17. Termination.** This agreement may be terminated by Seller for any reason and at any time by giving Buyer thirty (30) days written notice of termination. In addition, Seller may by written notice immediately terminate this agreement for the following: (a) Buyer commits a breach of any provision of this agreement (b) the appointment of a trustee, receiver or custodian for all or any part of Buyer's property (c) the filing of a petition for relief in bankruptcy of the other Party on its own behalf, or by a third party (d) an assignment for the benefit of creditors, or (e) the dissolution or liquidation of the Buyer.
- 18. Governing Law.** This agreement and the sale and delivery of all Products hereunder shall be deemed to have taken place in and shall be governed and construed in accordance with the laws of the State of Ohio, as applicable to contracts executed and wholly performed therein and without regard to conflicts of laws principles. Buyer irrevocably agrees and consents to the exclusive jurisdiction and venue of the courts of Cuyahoga County, Ohio with respect to any dispute, controversy or claim arising out of or relating to this agreement. Disputes between the parties shall not be settled by arbitration unless, after a dispute has arisen, both parties expressly agree in writing to arbitrate the dispute.
- 19. Indemnity for Infringement of Intellectual Property Rights.** Seller shall have no liability for infringement of any patents, trademarks, copyrights, trade dress, trade secrets or similar rights except as provided in this Section. Seller will defend and indemnify Buyer against allegations of infringement of U.S. patents, U.S. trademarks, copyrights, trade dress and trade secrets ("Intellectual Property Rights"). Seller will defend at its expense and will pay the cost of any settlement or damages awarded in an action brought against Buyer based on an allegation that a Product sold pursuant to this Agreement infringes the Intellectual Property Rights of a third party. Seller's obligation to defend and indemnify Buyer is contingent on Buyer notifying Seller within ten (10) days after Buyer becomes aware of such allegations of infringement, and Seller having sole control over the defense of any allegations or actions including all negotiations for settlement or compromise. If a Product is subject to a claim that it infringes the Intellectual Property Rights of a third party, Seller may, at its sole expense and option, procure for Buyer the right to continue using the Product, replace or modify the Product so as to make it non-infringing, or offer to accept return of the Product and return the purchase price less a reasonable allowance for depreciation. Notwithstanding the foregoing, Seller shall have no liability for claims of infringement based on information provided by Buyer, or directed to Products delivered hereunder for which the designs are specified in whole or part by Buyer, or infringements resulting from the modification, combination or use in a system of any Product sold hereunder. The foregoing provisions of this Section shall constitute Seller's sole and exclusive liability and Buyer's sole and exclusive remedy for infringement of Intellectual Property Rights.
- 20. Taxes.** Unless otherwise indicated, all prices and charges are exclusive of excise, sales, use, property, occupational or like taxes which may be imposed by any taxing authority upon the manufacture, sale or delivery of Products.
- 21. Equal Opportunity Clause.** For the performance of government contracts and where dollar value of the Products exceed \$10,000, the equal employment opportunity clauses in Executive Order 11246, VEVRRA, and 41 C.F.R. §§ 60-1.4(a), 60-741.5(a), and 60-250.4, are hereby incorporated.



Parker Hannifin Corporation
 6035 Parkland Blvd.
 Cleveland, Ohio 44124-4141
 Telephone: (216) 896-3000
 Fax: (216) 896-4000
 www.parker.com

Parker Hannifin Corporation

About Parker Hannifin Corporation

Parker Hannifin is a leading global motion-control company dedicated to delivering premier customer service. A Fortune 500 corporation listed on the New York Stock Exchange (PH), our components and systems comprise over 1,400 product lines that control motion in some 1,000 industrial and aerospace markets. Parker is the only manufacturer to offer its customers a choice of hydraulic, pneumatic, and electromechanical motion-control solutions. Our Company has the largest distribution network in its field, with over 7,500 distributors serving nearly 400,000 customers worldwide.

Parker's Charter

To be a leading worldwide manufacturer of components and systems for the builders and users of durable goods. More specifically, we will design, market and manufacture products controlling motion, flow and pressure. We will achieve profitable growth through premier customer service.

Product Information

North American customers seeking product information, the location of a nearby distributor, or repair services will receive prompt attention by calling the Parker Product Information Center at our toll-free number: 1-800-C-PARKER (1-800-272-7537). In Europe, call 00800-C-PARKER-H (00800-2727-5374).

The Aerospace Group

is a leader in the development, design, manufacture and servicing of control systems and components for aerospace and related high-technology markets, while achieving growth through premier customer service.



The Climate & Industrial Controls Group

designs, manufactures and markets system-control and fluid-handling components and systems to refrigeration, air-conditioning and industrial customers worldwide.



The Fluid Connectors Group

designs, manufactures and markets rigid and flexible connectors, and associated products used in pneumatic and fluid systems.



The Seal Group designs, manufactures and distributes industrial and commercial sealing devices and related products by providing superior quality and total customer satisfaction.



The Hydraulics Group

designs, produces and markets a full spectrum of hydraulic components and systems to builders and users of industrial and mobile machinery and equipment.



The Filtration Group

designs, manufactures and markets quality filtration and clarification products, providing customers with the best value, quality, technical support, and global availability.



The Automation Group is a leading supplier of pneumatic and electromechanical components and systems to automation customers worldwide.



The Instrumentation Group is a global leader in the design, manufacture and distribution of high-quality critical flow components for worldwide process instrumentation, ultra-high-purity, medical and analytical applications.



Parker Hannifin Corporation
Mobile Cylinder Div.
P.O. Box 239
Youngstown, OH 44501-0239
phone (330) 480-8431
fax (330) 480-8432
www.parker.com

